

**Architects** - These concepts have been expanded and modified to afford you design freedom. Please contact your Kawneer representative for further assistance. The extrusions and window types illustrated in this catalog are standard products for Kawneer.

**FEATURES** ..... 2

**PICTORIAL VIEW** ..... 3

**FRAMING DETAILS** ..... 4

**MISCELLANEOUS DETAILS** ..... 5

**THERMAL TRANSMITTANCE** ..... 6

**STRUCTURAL LIMITATIONS** ..... 7, 8

LAWS AND BUILDING AND SAFETY CODES GOVERNING THE DESIGN AND USE OF GLAZED ENTRANCE, WINDOW, AND CURTAIN WALL PRODUCTS VARY WIDELY. KAWNEER DOES NOT CONTROL THE SELECTION OF PRODUCT CONFIGURATIONS, OPERATING HARDWARE, OR GLAZING MATERIALS, AND ASSUMES NO RESPONSIBILITY THEREFOR.

Metric (SI) conversion figures are included throughout these details for reference. Numbers in parentheses ( ) are millimeters unless otherwise noted.

The following metric (SI) units are found in these details:

- m - meter
- cm - centimeter
- mm - millimeter
- s - second
- Pa - pascal
- MPa - megapascal

Kawneer reserves the right to change configurations without prior notice when deemed necessary for product improvement.

Laws and building and safety codes governing the design and use of glazed entrance, window, and curtain wall products vary widely. Kawneer does not control the selection of product configurations, operating hardware, or glazing materials, and assumes no responsibility therefor.

Kawneer reserves the right to change configuration without prior notice when deemed necessary for product improvement.

© Kawneer Company, Inc., 2011

- 19/32" (14.6 mm) ISOPORT® glass-reinforced nylon 6/6 thermal break provides:
  - Improved condensation resistance and thermal transmittance performance capability
  - Rigid profile with composite structural performance
  - Exterior / interior finish options
- Meets or exceeds the highest performance levels of CSA standard CAN/CSA-A440 windows
- Seamless coupling mullion features unbroken weather joints on exterior surface
- Provision for thermal movement
- Simple joinery with overlapping flanges for economical construction and good weathering capability
- Optional full rain screen capability
- Accommodates 1" sealed glazing units
- Glass installed and replaced from interior
- Exterior pre-shim butyl glazing tapes
- Interior EPDM rubber glazing gaskets
- Lock-in glass stop
- Companion open-out or open-in vent inserts available
- Accepts 512 Ventrow® inserts

Laws and building and safety codes governing the design and use of glazed entrance, window, and curtain wall products vary widely. Kawneer does not control the selection of product configurations, operating hardware, or glazing materials, and assumes no responsibility therefor.

Kawneer reserves the right to change configuration without prior notice when deemed necessary for product improvement.  
© Kawneer Company, Inc., 2011

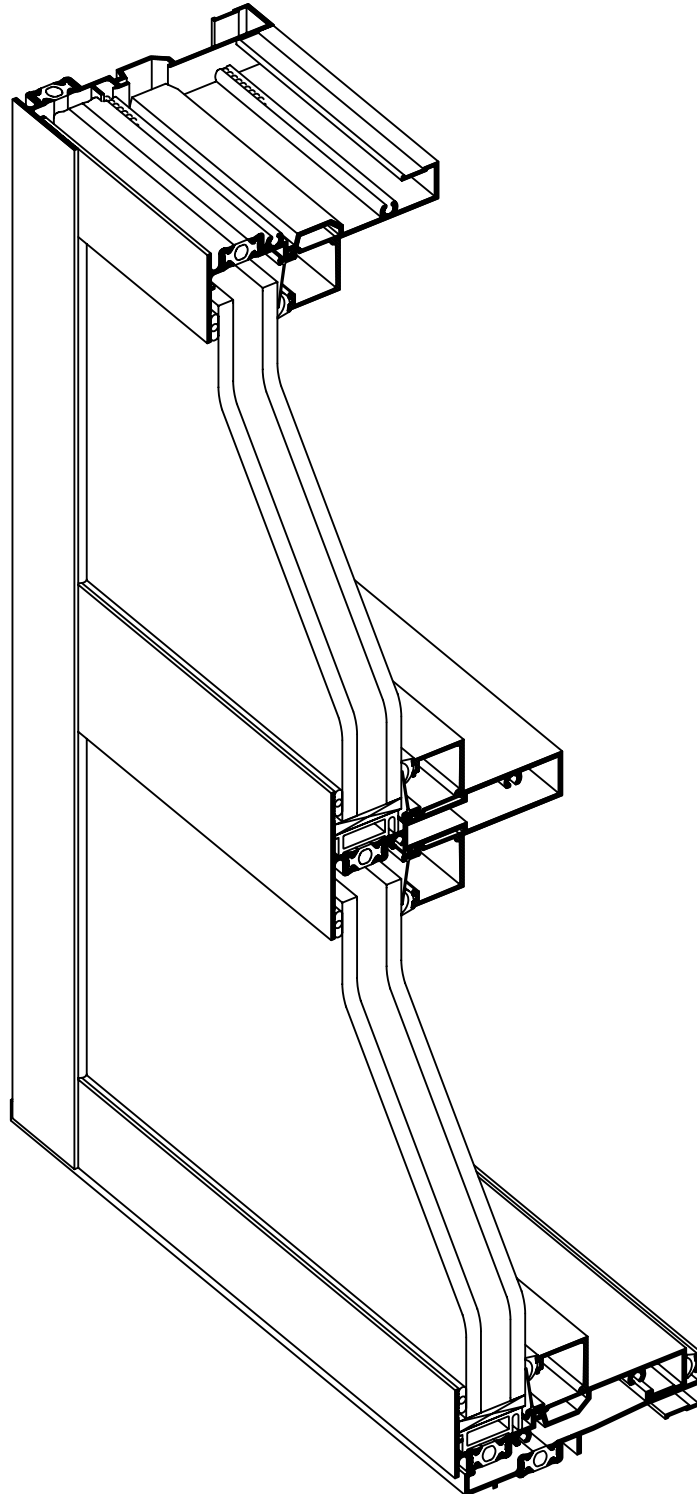

Laws and building and safety codes governing the design and use of glazed entrance, window, and curtain wall products vary widely. Kawneer does not control the selection of product configurations, operating hardware, or glazing materials, and assumes no responsibility therefor.

Kawneer reserves the right to change configuration without prior notice when deemed necessary for product improvement.

© Kawneer Company, Inc., 2011

SCALE: 1/4 FULL SIZE

**TYPE A**

**HORIZONTAL STRIP WINDOW**

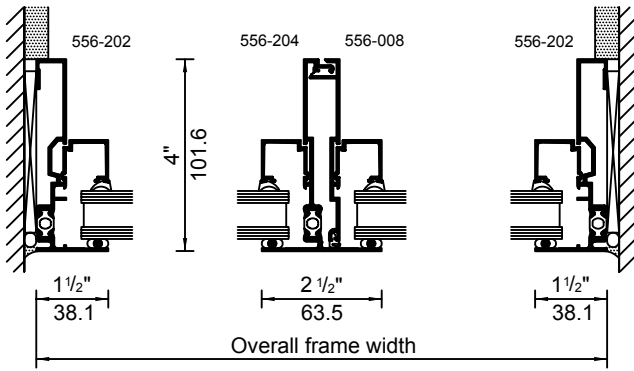
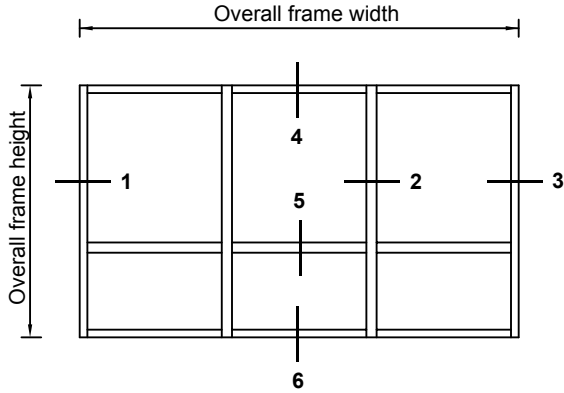

**1 JAMB**      **2 COUPLING MULLION**      **3 JAMB**

**TYPE B**

**MULTI-MODULAR STRIP WINDOW OR PUNCHED OPENING**

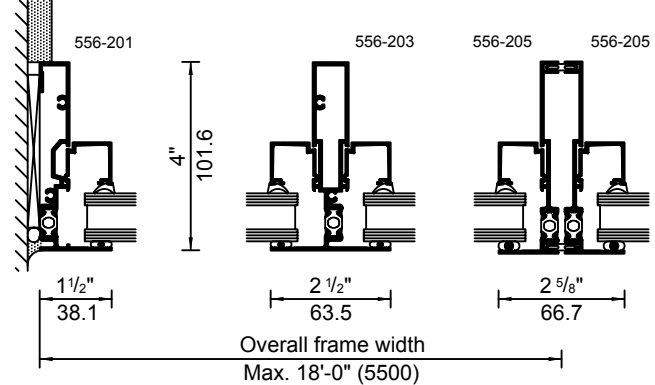
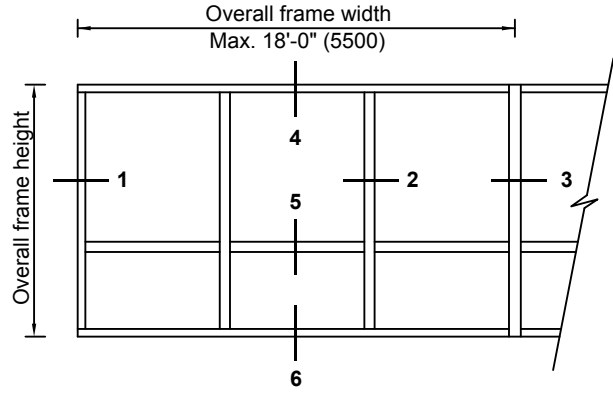

**1 JAMB**      **2 TUBULAR MULLION**      **3 MULTI-MODULAR COUPLING MULLION**

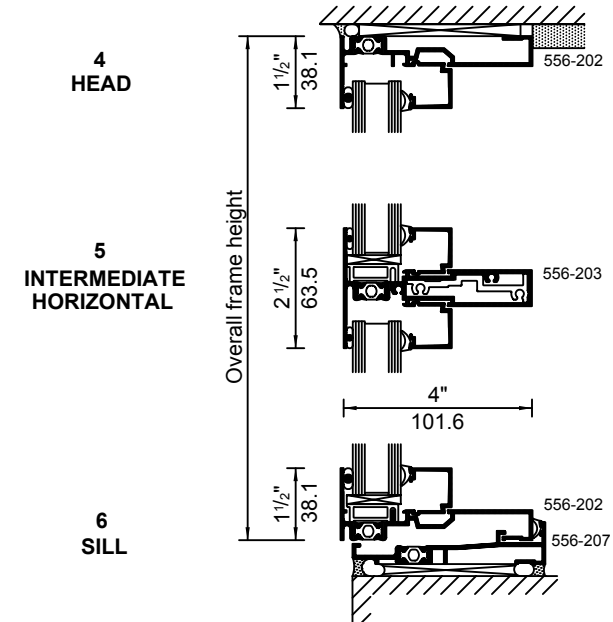
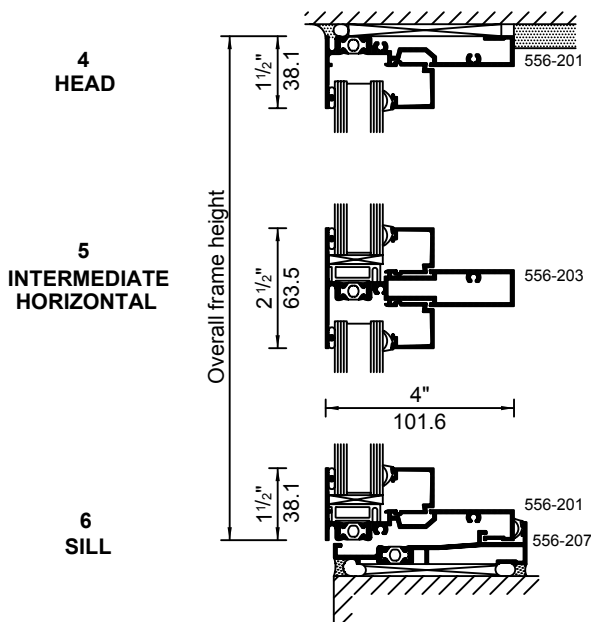

Laws and building and safety codes governing the design and use of glazed entrance, window, and curtain wall products vary widely. Kawneer does not control the selection of product configurations, operating hardware, or glazing materials, and assumes no responsibility therefor.

Kawneer reserves the right to change configuration without prior notice when deemed necessary for product improvement.  
© Kawneer Company, Inc., 2011

SCALE: 1/4 FULL SIZE

90° INSIDE CORNER

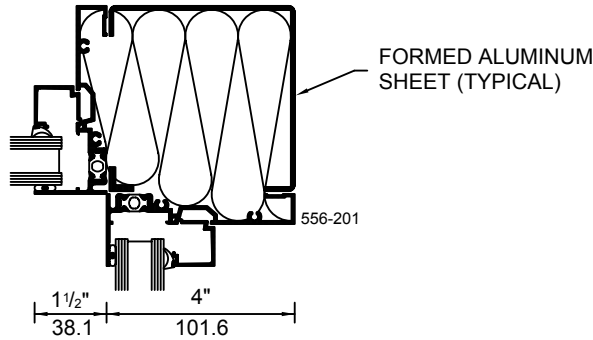

90° OUTSIDE CORNER

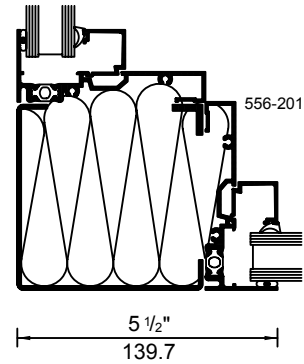

DEFLECTION HEAD  
(ALLOWS ± 5/8" (15.9) MOVEMENT)

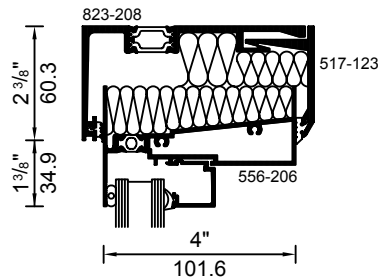

RAIN SCREEN WINDOW

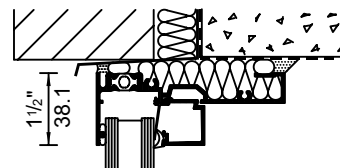

**NOTE:**  
BUILDING INTERFACE DETAILS  
VARY WIDELY AND ARE  
SIMPLIFIED HERE FOR CLARITY.

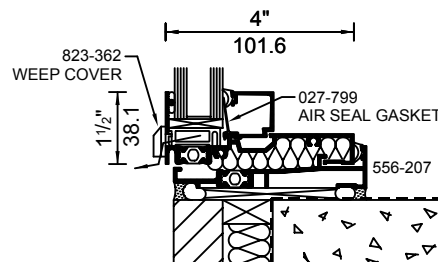
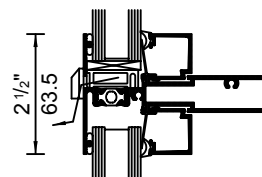

Laws and building and safety codes governing the design and use of glazed entrance, window, and curtain wall products vary widely. Kawneer does not control the selection of product configurations, operating hardware, or glazing materials, and assumes no responsibility therefor.

Kawneer reserves the right to change configuration without prior notice when deemed necessary for product improvement.  
© Kawneer Company, Inc., 2011

For some regions and projects there may be minimum energy efficiency requirements for the building envelope, and its components, including windows. The shading coefficient (SC) and the thermal transmittance (U - value) of the window is then required to determine whether the building design complies with the specified energy requirements. Shading coefficient depends on the glass selected and should be obtained from the glass supplier. The U - value of the window varies with the type of glass and sealed unit edge construction, the window frame, and the relative areas of these components.

The window thermal transmittance values (U - values) shown in the chart below are based on CSA - A440.2 "Energy Performance Evaluation of Windows and Sliding Glass Doors". U - values of the centre of glass, edge of glass and frame areas were computed using the VISION and FRAME thermal simulation programs. Overall window U - values were calculated using the following relationship:

$$U_w = (U_c A_c + U_e A_e + U_f A_f) / A_w$$

where

$U_w$  = U-value of complete window product

$U_c$  = calculated centre of glass U-value

$U_e$  = calculated edge of glass U-value

$U_f$  = calculated frame U-value

$A_c$  = centre of glass area

$A_e$  = edge of glass area

$A_f$  = frame area

$A_w$  = total window area

### OVERALL WINDOW U-VALUE ( $U_w$ )

For fixed window configurations as shown with height (h) equal to width (w).

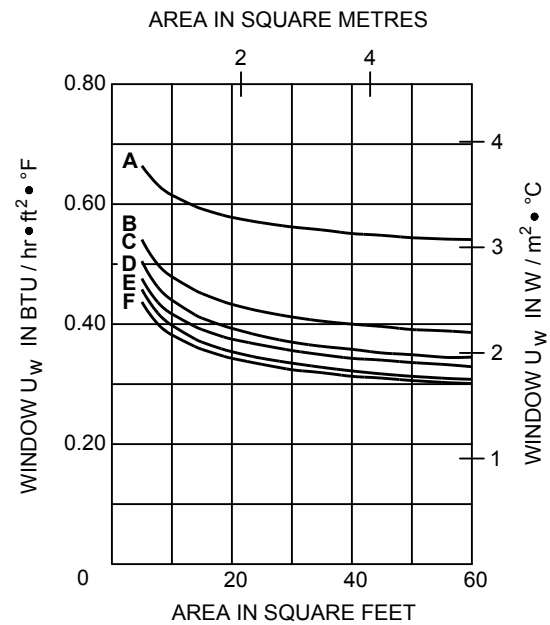
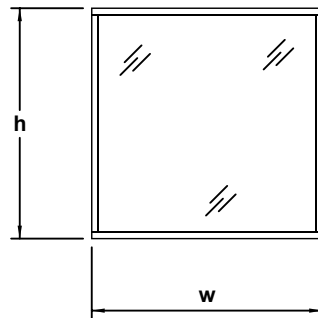

#### SEALED UNIT GLAZING TYPE

A = 6mm clear / 1/2" air / 6mm clear / metal spacer

B = 6mm clear / 1/2" air / 6mm low-e<sup>1</sup> / metal spacer

C = 6mm clear / 1/2" argon / 6mm low-e<sup>1</sup> / metal spacer

D = 6mm clear / 1/2" argon / 6mm low-e<sup>1</sup> / Helima thermally broken spacer

E = 6mm clear / 1/2" argon / 6mm low-e<sup>2</sup> / Helima thermally broken spacer

F = 6mm clear / 1/2" argon / 6mm low-e<sup>2</sup> / Edgetech Super Spacer®

1 - low-e coating emittance = 0.10

2 - low-e coating emittance = 0.03

**NOTES:** THE ABOVE SEALED UNIT GLAZING OPTIONS ARE PRESENTED FOR THE PURPOSES OF ILLUSTRATING THERMAL PERFORMANCE CAPABILITIES.

FOR WINDOWS WITH HEIGHT NOT EQUAL TO WIDTH, WHEN ADDING INTERMEDIATE VERTICALS OR HORIZONTALS, OR DIFFERENT GLASS INFILL, THE OVERALL WINDOW U - VALUE MAY VARY.

THE SPECIFIER SHOULD SELECT GLASS TO MEET THE PERFORMANCE REQUIREMENTS OF THE PROJECT.

Laws and building and safety codes governing the design and use of glazed entrance, window, and curtain wall products vary widely. Kawneer does not control the selection of product configurations, operating hardware, or glazing materials, and assumes no responsibility therefor.

Kawneer reserves the right to change configuration without prior notice when deemed necessary for product improvement.

© Kawneer Company, Inc., 2011

Calculations are based on CAN3-S157 "Strength Design in Aluminum" in accordance with the National Building Code of Canada and an allowable deflection of 1/175 of mullion span.

WINDLOAD LIMITATIONS

WITHOUT HORIZONTALS

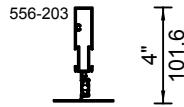
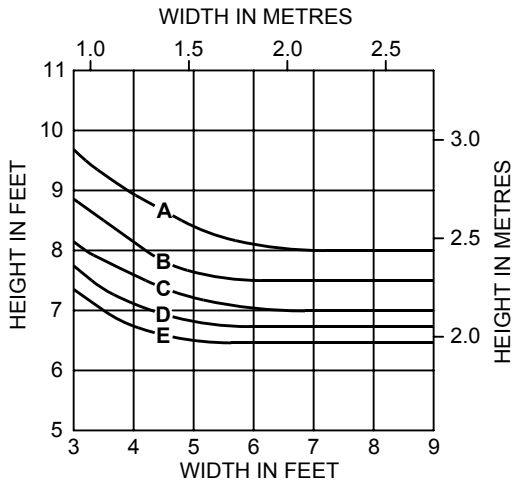

WITH HORIZONTALS

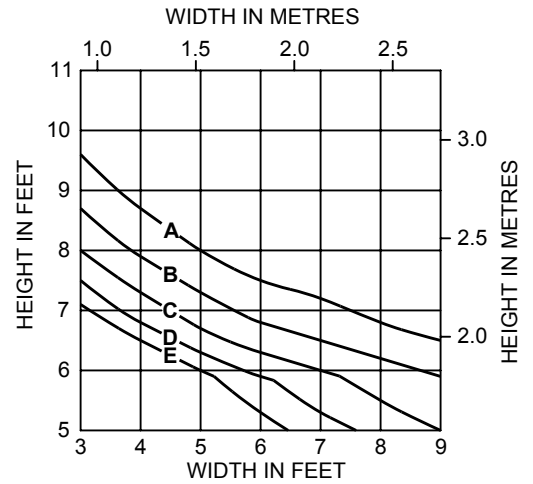

- A = 15 p.s.f. (0.72 kPa.)
- B = 20 p.s.f. (0.96 kPa.)
- C = 25 p.s.f. (1.20 kPa.)
- D = 30 p.s.f. (1.44 kPa.)
- E = 35 p.s.f. (1.68 kPa.)

WITHOUT HORIZONTALS

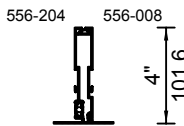
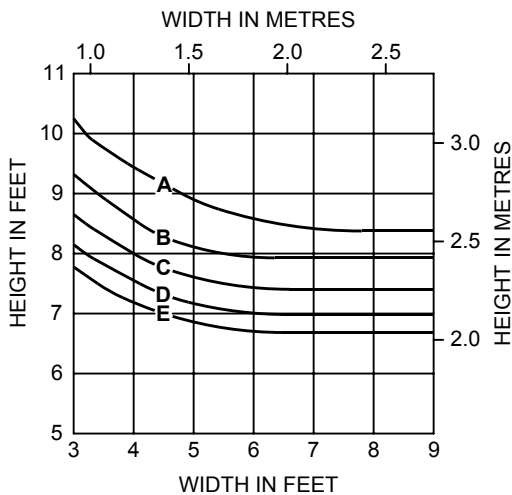

WITH HORIZONTALS

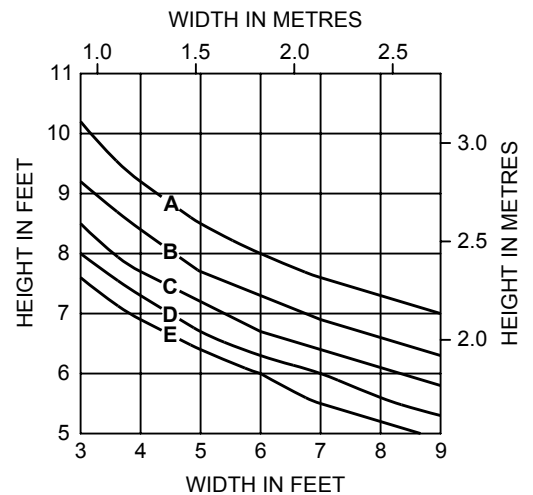

Laws and building and safety codes governing the design and use of glazed entrance, window, and curtain wall products vary widely. Kawneer does not control the selection of product configurations, operating hardware, or glazing materials, and assumes no responsibility therefor.

Kawneer reserves the right to change configuration without prior notice when deemed necessary for product improvement.

© Kawneer Company, Inc., 2011

Calculations are based on CAN3-S157 "Strength Design in Aluminum" in accordance with the National Building Code of Canada and an allowable deflection of 1/175 of mullion span.

WINDLOAD LIMITATIONS

WITHOUT HORIZONTALS

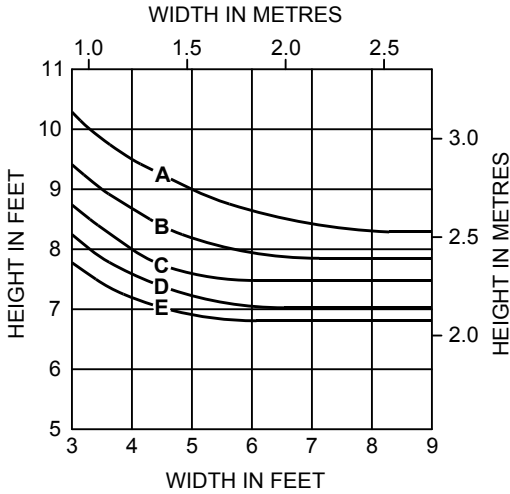

WITH HORIZONTALS

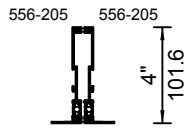
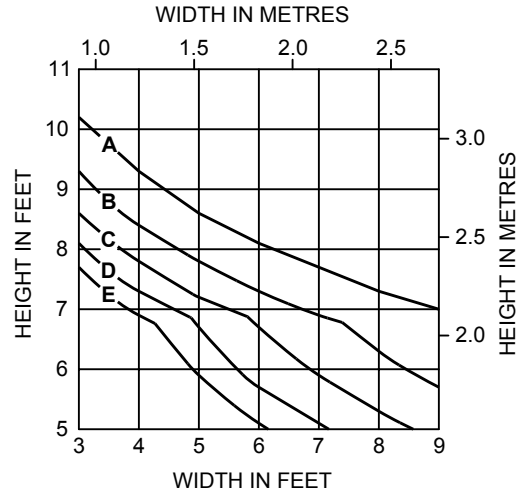

- A = 15 p.s.f. (0.72 kPa.)
- B = 20 p.s.f. (0.96 kPa.)
- C = 25 p.s.f. (1.20 kPa.)
- D = 30 p.s.f. (1.44 kPa.)
- E = 35 p.s.f. (1.68 kPa.)

DEADLOAD LIMITATIONS

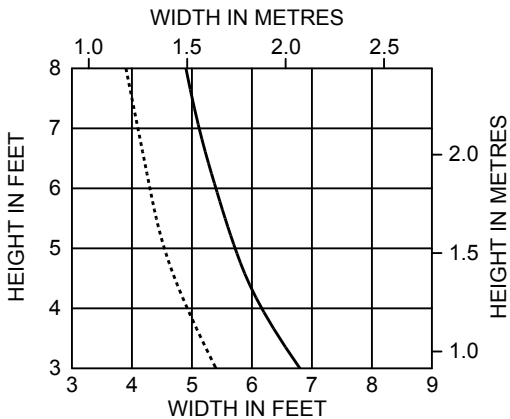

- ..... Intermediate Horizontal Over Ventilator (Maximum Deflection 1/16")
- Intermediate Horizontal Over Fixed Lite (Maximum Deflection 1/8")

Intermediate Horizontal 556-203

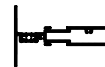

I = 0.12 in<sup>4</sup> (0.05 x 10<sup>6</sup> mm<sup>4</sup>)  
S = 0.09 in<sup>3</sup> (0.15 x 10<sup>4</sup> mm<sup>3</sup>)

Curves are for 25 mm ( 1" ) sealed units with (2) 6 mm (1/4") lites with setting blocks 3" (76 mm) from the ends of the lite.

Laws and building and safety codes governing the design and use of glazed entrance, window, and curtain wall products vary widely. Kawneer does not control the selection of product configurations, operating hardware, or glazing materials, and assumes no responsibility therefor.

Kawneer reserves the right to change configuration without prior notice when deemed necessary for product improvement.  
© Kawneer Company, Inc., 2011