

7500 Wall®

A Marriage of Energy Savings
and Design Freedom



PCL Centennial Learning Centre, Edmonton, Alberta, Canada
Architects: Cohos Evamy integratedesign™, Edmonton, Alberta, Canada
Glazing Contractor: Beacon Glass Products Ltd., St. Albert, Alberta, Canada

Kawneer's 7500 Wall® offers uncompromising design with uncompromising energy efficiency. It is the complete performer in all conditions, whether the application is a curtain wall, ground floor framing or strip windows. With the flexibility of a three-piece system, it provides design freedom and dual finish options. Thermal breaks and double or triple glazing options provide a real reduction in energy usage and significant savings in HVAC capital costs.

Performance

A high-performance system like this sets the pace in curtain wall technology and leads the way as an energy efficient product. It has been designed and developed for applications where the primary concerns are energy efficiency and reduced payback time periods.

A 24 mm and 49 mm ISOWEB® glass-reinforced nylon thermal break provides rigid profiles with composite structural performance. The 7525 framing accommodates 1" (25.4) high performance double sealed units and 7550 framing accommodates 2" (50.8) high

performance triple sealed units. 7500 Wall®, with a fully pressure equalized, rain screen design, also has an EPDM sponge interior and EPDM rubber exterior gaskets (dry/dry glazing).

7500 Wall® system has been tested and certified to meet the following standards:

- Air infiltration per ASTM E283 < 0.06 cfm/ft², pressure differential of 6.24 psf (300 Pa)
- Water penetration per ASTM E547 no water infiltration with a pressure differential of 15 psf (720 Pa)
- Thermal transmittance per AAMA 1503 up to 0.17 BTU/hr x ft² x °F (0.98 W/m² x °C)
- 7550 Wall with triple glazing offers a CRF_f = 85 and CRF_g = 80
- Improved condensation temperature index I value
- Meets or exceeds the highest levels of CSA standard CAN/CSA-A440 Windows

Aesthetics

The 7500 Wall® system combines slim sightlines with an overall aesthetically pleasing appearance. The system is ideal for storefronts, strip windows, window/wall or curtain wall applications.

A 4" (101.6) standard mullion depth and a narrow 2-1/2" (63.5) sightline are characteristic of the 7500 Wall®. It offers greater design flexibility with the options to select a grid pattern type, different product finishes, various glass types and choice of spandrel infills. All infill materials are glazed from the exterior and held in place with mechanically fastened continuous pressure plates. The system is also compatible for use with Insulclad® doors.

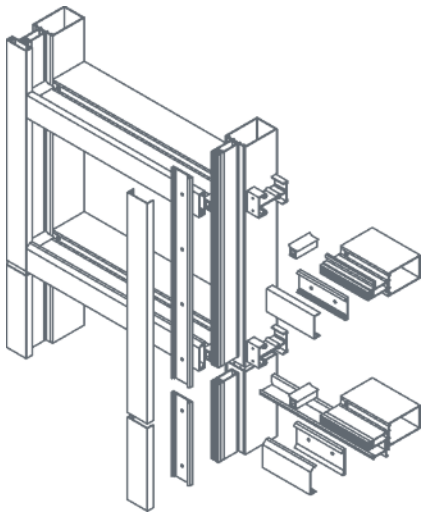

Tubular mullions and transoms with shear block construction. Pressure equalized rain screen design. High-performance ISOWEB® glass reinforced nylon thermal break. 7550 Wall shown, 7525 Wall similar.

Note: Numbers in parentheses () are millimeters unless otherwise noted.

Kawneer Company, Inc.
Technology Park / Atlanta
555 Guthridge Court
Norcross, GA 30092

kawneer.com
kawneergreen.com
770 . 449 . 5555

© Kawneer Company, Inc. 2011 LITHO IN U.S.A. Form No. 11-2136



University of Alaska Museum of the North, Fairbanks, AK
Architects: GDM Inc., Anchorage, AK; Hammel, Green and Abrahamson, Inc. (HGA), Minneapolis, MN
Glazing Contractor: Commercial Contractors, Inc., Anchorage, AK

For the Finishing Touch

Permanodic® Anodized finishes are available in Class I and Class II in seven different color choices.

Painted finishes, including fluoropolymer, that meet AAMA 2605 are offered in many standard choices and an unlimited number of specially-designed colors.

Solvent-free powder coatings add the green element with high performance, durability and scratch resistance that meet the standards of AAMA 2604.

 **KAWNEER**
AN ALCOA COMPANY