

Features

- Economical
- 2-1/4" sight line
- 1" infill system has 5" or 7-1/4" depth members
- 1/4" infill system has 4-1/4" or 6-1/2" depth members
- Outside glazed
- SSG option for vertical mullions
- Thermal break via polymer glazing clip
- Permanodic™ anodized finishes in seven choices
- Painted finishes in standard and custom choices

Optional Features

- Two color capability
- Project specific U-factors (See Thermal Charts)

Product Applications

- Low-rise curtain wall applications of four stories or less
- Punched opening or ribbon window applications
- Integrated entrance framing allowing Kawneer entrances or other specialty entrances to be included
- Integrates with GLASSvent™ windows for curtain wall

For specific product applications,
Consult your Kawneer representative.

Laws and building and safety codes governing the design and use of glazed entrance, window, and curtain wall products vary widely. Kawneer does not control the selection of product configurations, operating hardware, or glazing materials, and assumes no responsibility therefor.

Kawneer reserves the right to change configuration without prior notice when deemed necessary for product improvement.
© Kawneer Company, Inc., 2013

Architects – Most extrusion and window types illustrated in this catalog are standard products for Kawneer. These concepts have been expanded and modified to afford you design freedom. Some miscellaneous details are non-standard and are intended to demonstrate how the system can be modified to expand design flexibility. Please contact your Kawneer representative for further assistance.

PICTORIAL VIEW 5

1/4 SIZE DETAILS (1" SYSTEM) 6, 7

1/4 SIZE DETAILS (1/4" SYSTEM) 8, 9

ANCHORING 10

WIND LOAD CHARTS 11-14

DEADLOAD CHARTS 15-16

THERMAL CHARTS 17-24

LAWS AND BUILDING AND SAFETY CODES GOVERNING THE DESIGN AND USE OF GLAZED ENTRANCE, WINDOW, AND CURTAIN WALL PRODUCTS VARY WIDELY. KAWNEER DOES NOT CONTROL THE SELECTION OF PRODUCT CONFIGURATIONS, OPERATING HARDWARE, OR GLAZING MATERIALS, AND ASSUMES NO RESPONSIBILITY THEREFOR.

Metric (SI) conversion figures are included throughout these details for reference. Numbers in parentheses () are millimeters unless otherwise noted.

The following metric (SI) units are found in these details:

- m – meter
- cm – centimeter
- mm – millimeter
- s – second
- Pa – pascal
- MPa – megapascal

Laws and building and safety codes governing the design and use of glazed entrance, window, and curtain wall products vary widely. Kawneer does not control the selection of product configurations, operating hardware, or glazing materials, and assumes no responsibility therefor.

Kawneer reserves the right to change configuration without prior notice when deemed necessary for product improvement.
© Kawneer Company, Inc., 2013

Laws and building and safety codes governing the design and use of glazed entrance, window, and curtain wall products vary widely. Kawneer does not control the selection of product configurations, operating hardware, or glazing materials, and assumes no responsibility therefor.

Kawneer reserves the right to change configuration without prior notice when deemed necessary for product improvement.
© Kawneer Company, Inc., 2013

Laws and building and safety codes governing the design and use of glazed entrance, window, and curtain wall products vary widely. Kawneer does not control the selection of product configurations, operating hardware, or glazing materials, and assumes no responsibility therefor.

Kawneer reserves the right to change configuration without prior notice when deemed necessary for product improvement.
© Kawneer Company, Inc., 2013

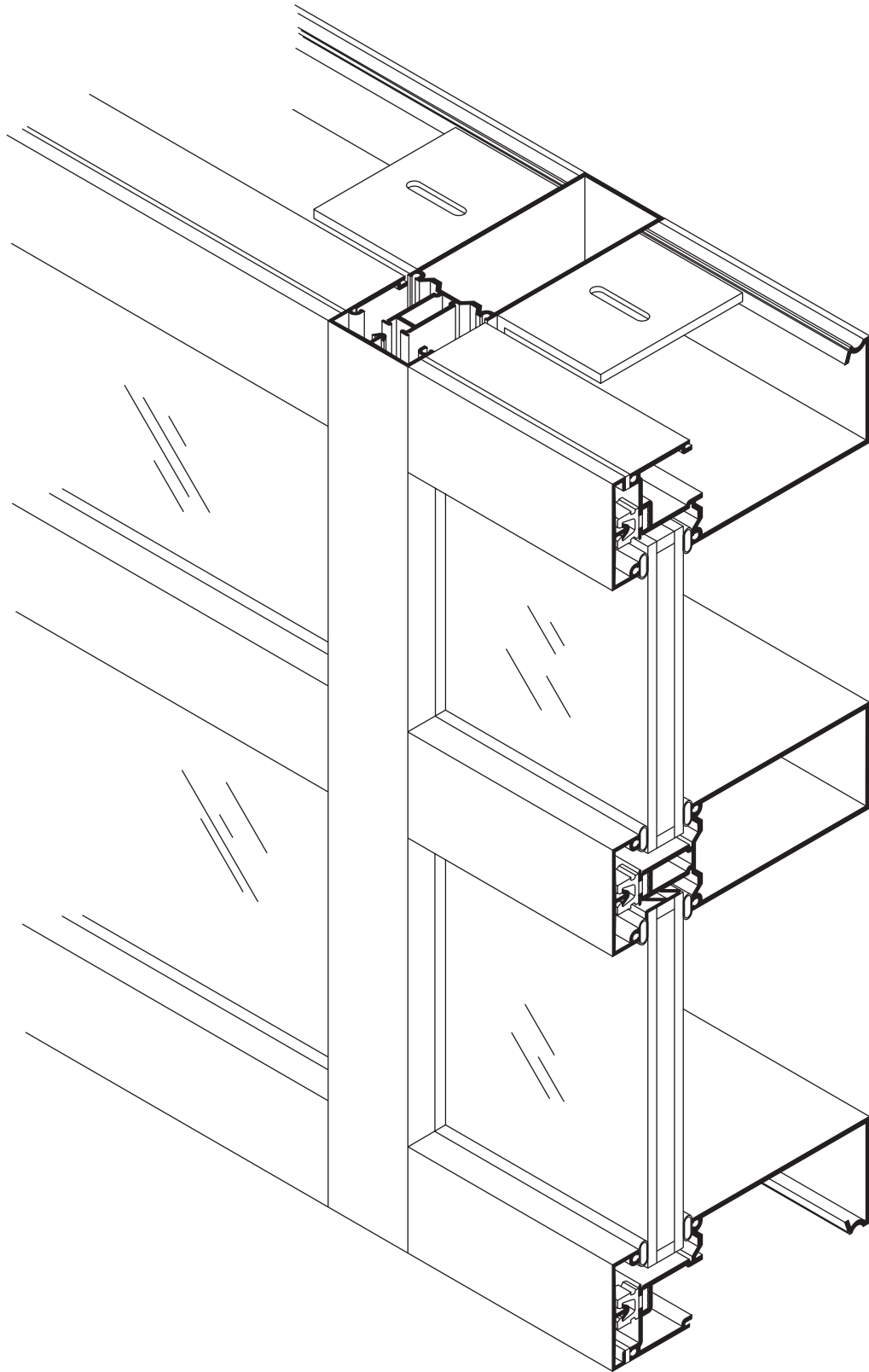

SCALE 3" = 1'-0"

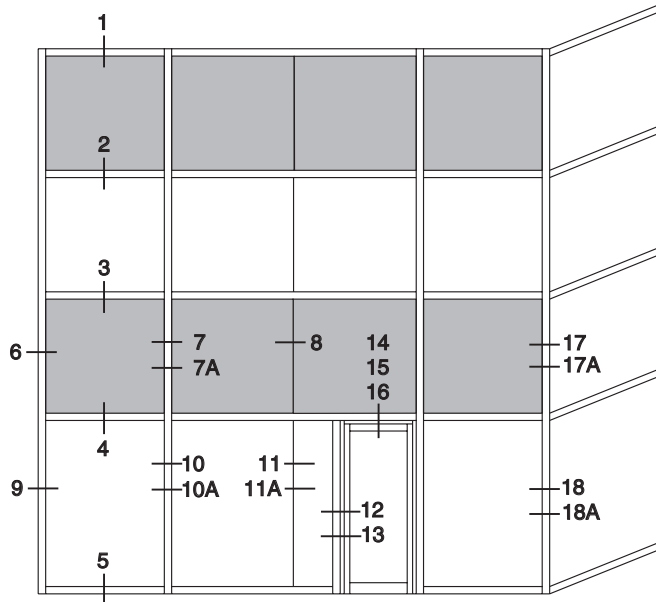

ELEVATION IS NUMBER KEYED TO DETAILS

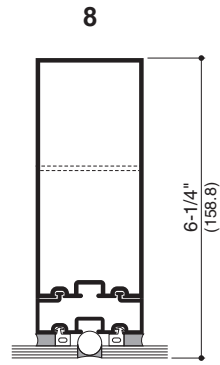
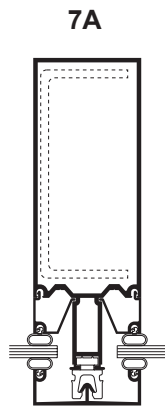
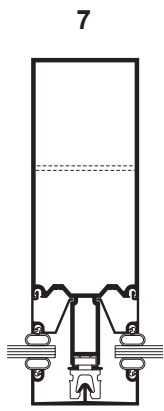
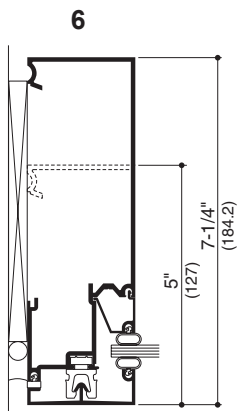
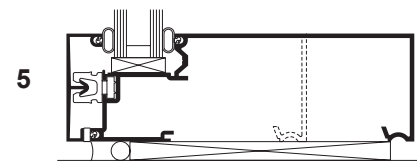
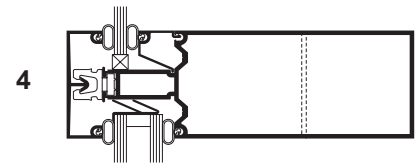
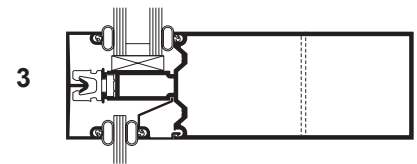
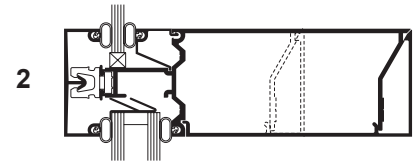
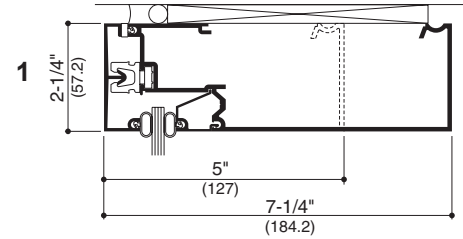

SSG MULLION

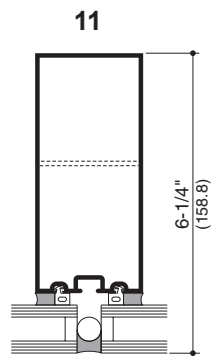
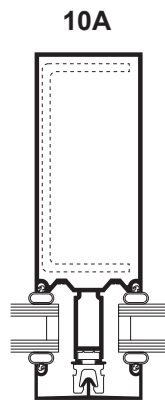
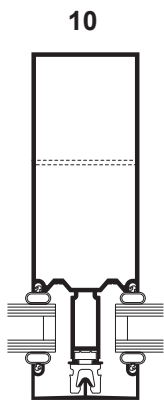
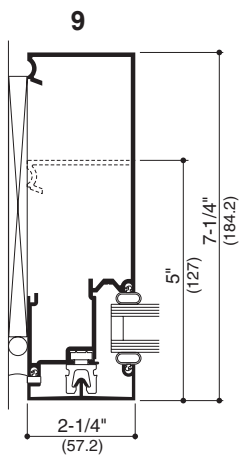

SSG MULLIONS

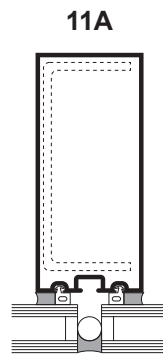

Laws and building and safety codes governing the design and use of glazed entrance, window, and curtain wall products vary widely. Kawneer does not control the selection of product configurations, operating hardware, or glazing materials, and assumes no responsibility therefor.

Kawneer reserves the right to change configuration without prior notice when deemed necessary for product improvement.
© Kawneer Company, Inc., 2013

SCALE 3" = 1'-0"

SECTIONS ARE NUMBER KEYED TO ELEVATION ON PAGE 6.

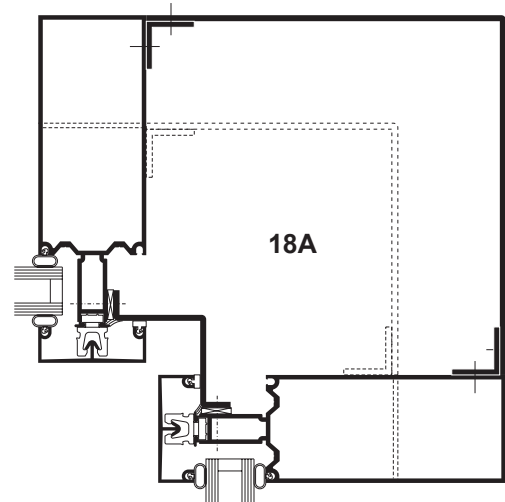
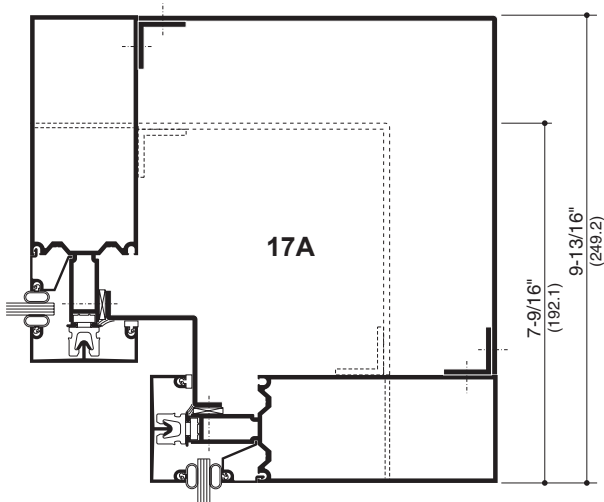
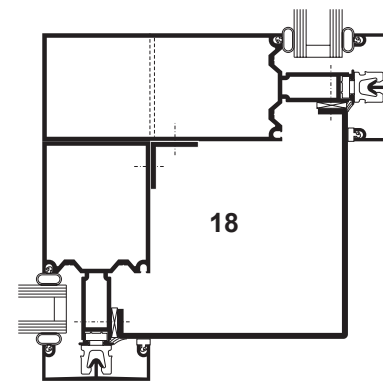
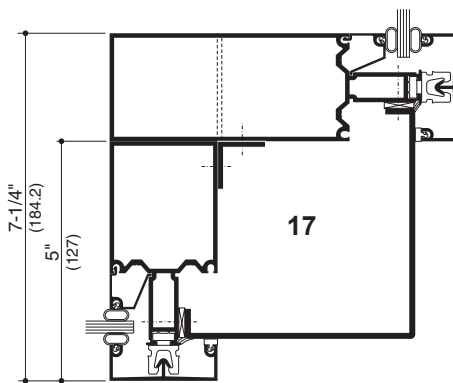
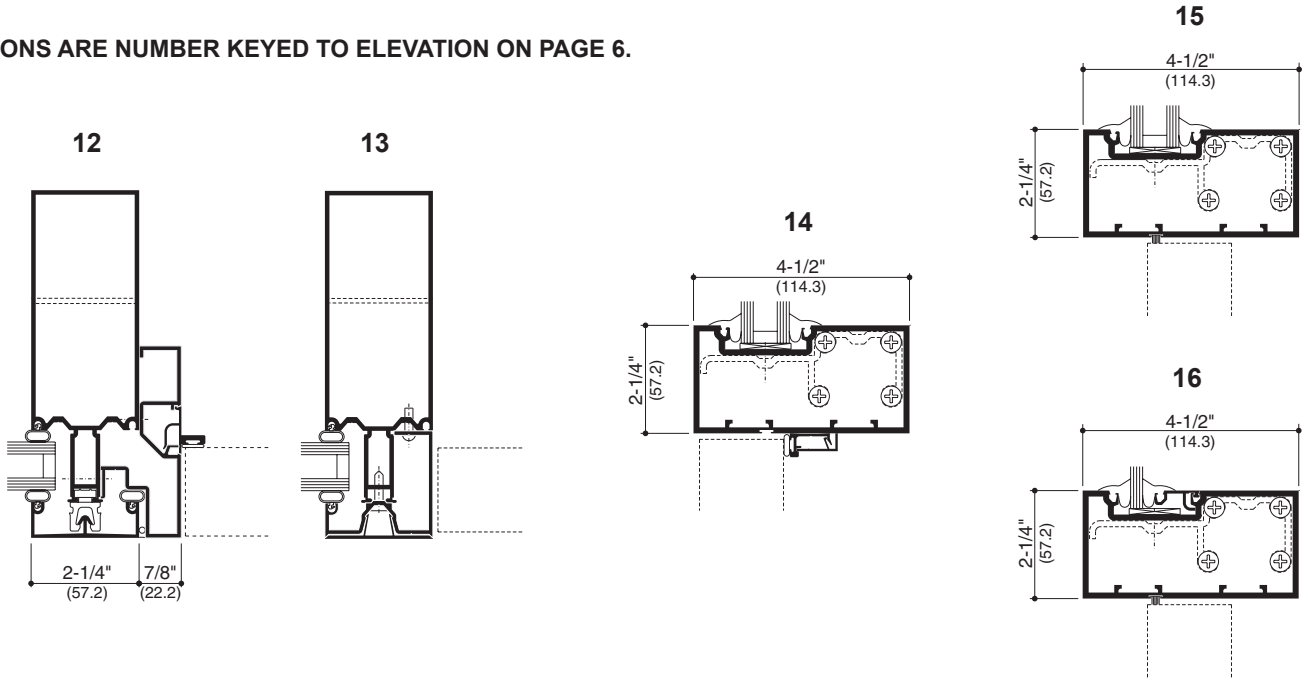

Laws and building and safety codes governing the design and use of glazed entrance, window, and curtain wall products vary widely. Kawneer does not control the selection of product configurations, operating hardware, or glazing materials, and assumes no responsibility therefor.

Kawneer reserves the right to change configuration without prior notice when deemed necessary for product improvement.

© Kawneer Company, Inc., 2013

SCALE 3" = 1'-0"

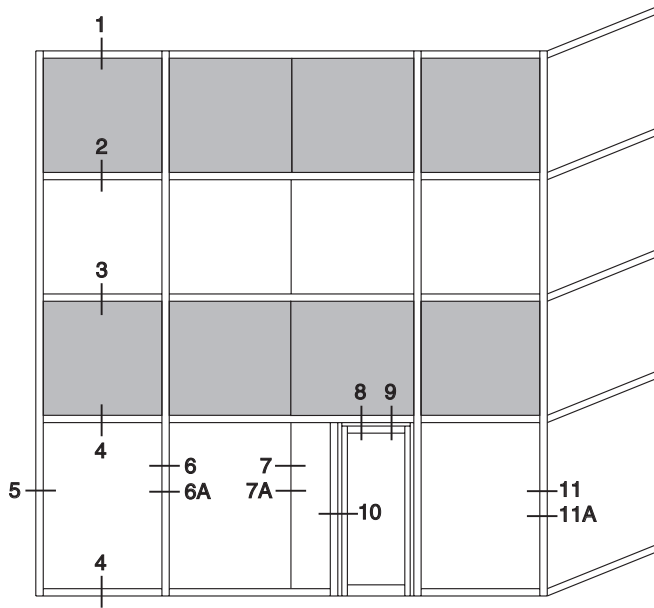

ELEVATION IS NUMBER KEYED TO DETAILS

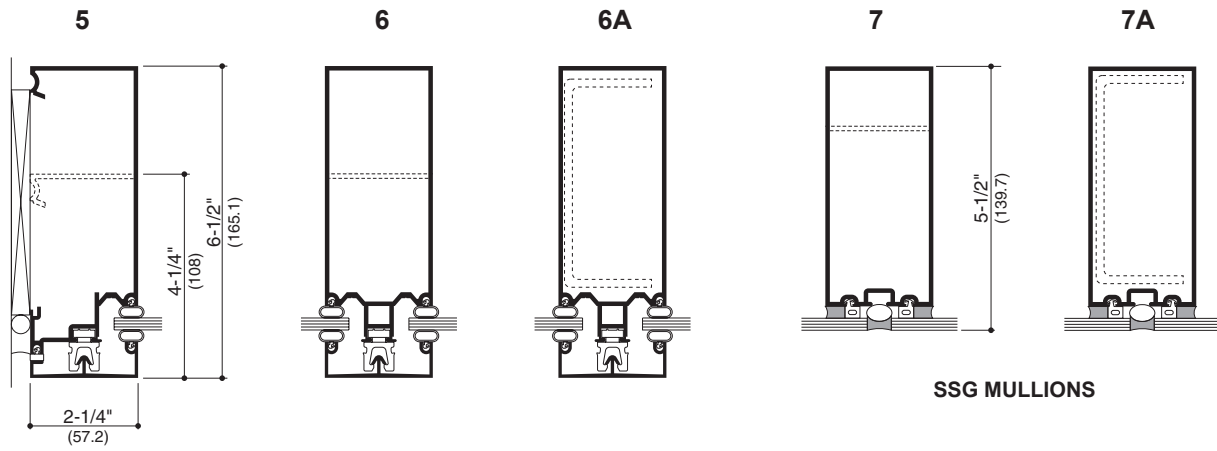
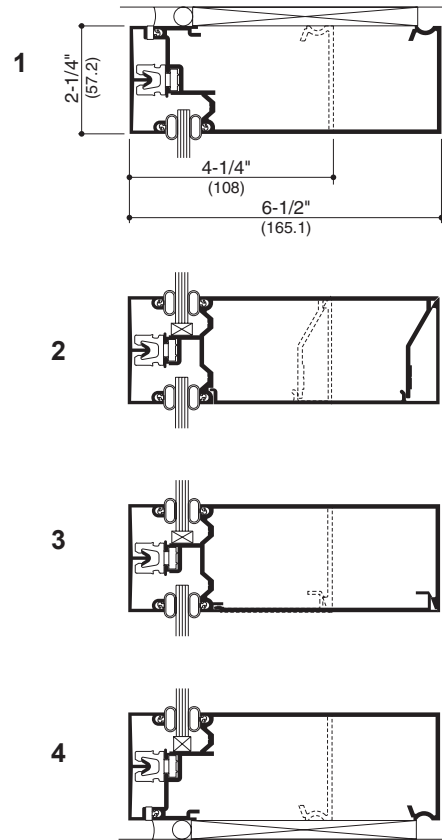

SSG MULLIONS

Laws and building and safety codes governing the design and use of glazed entrance, window, and curtain wall products vary widely. Kawneer does not control the selection of product configurations, operating hardware, or glazing materials, and assumes no responsibility therefor.

Kawneer reserves the right to change configuration without prior notice when deemed necessary for product improvement.
© Kawneer Company, Inc., 2013

SCALE 3" = 1'-0"

SECTIONS ARE NUMBER KEYED TO ELEVATION ON PAGE 8.

Laws and building and safety codes governing the design and use of glazed entrance, window, and curtain wall products vary widely. Kawneer does not control the selection of product configurations, operating hardware, or glazing materials, and assumes no responsibility therefor.

Kawneer reserves the right to change configuration without prior notice when deemed necessary for product improvement.
© Kawneer Company, Inc., 2013

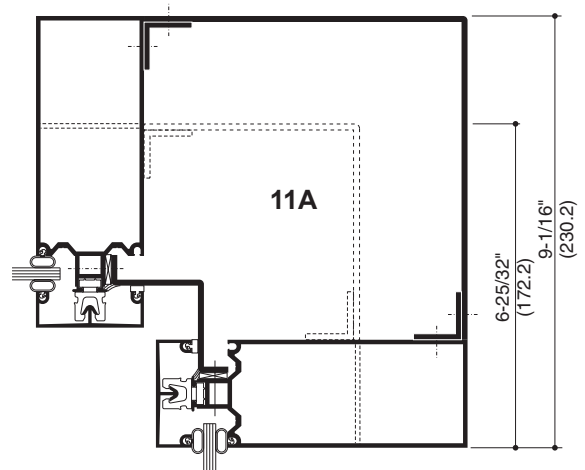
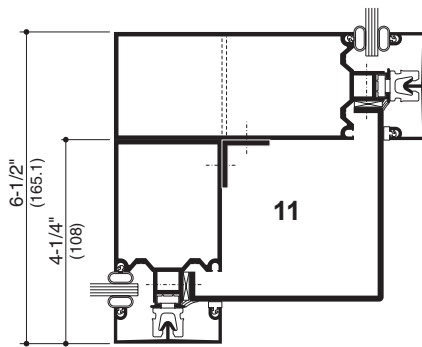
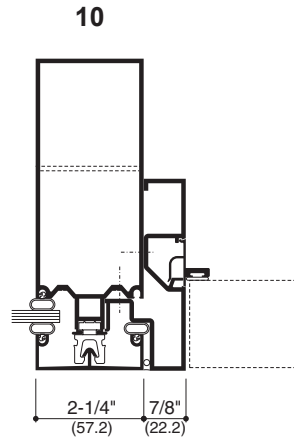
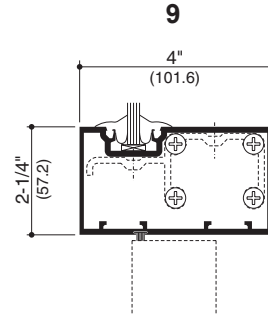
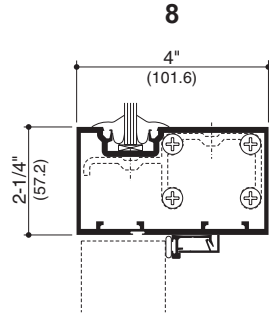

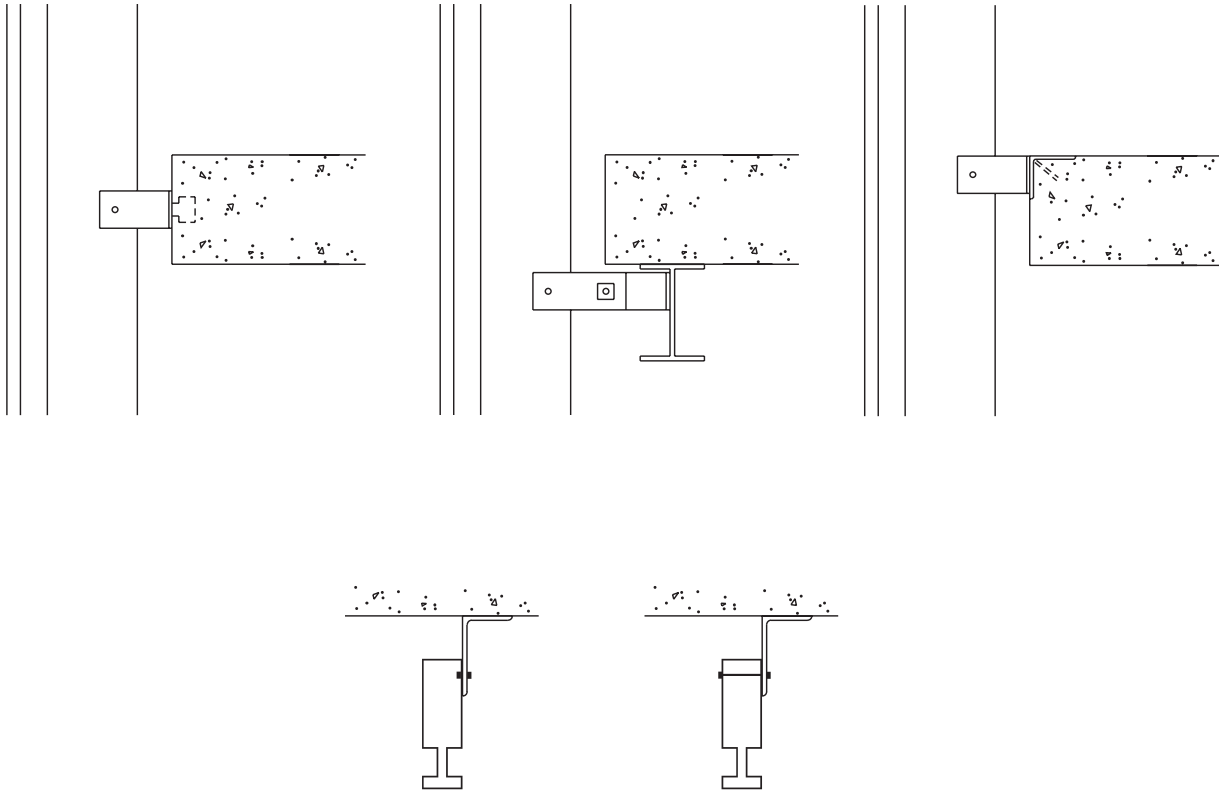
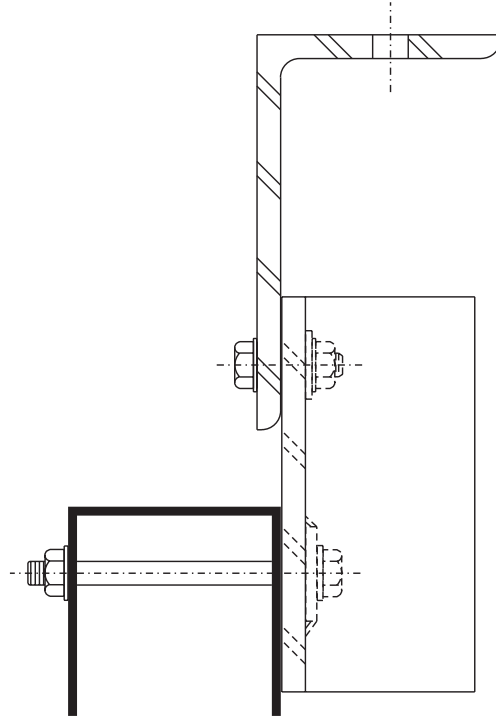

Laws and building and safety codes governing the design and use of glazed entrance, window, and curtain wall products vary widely. Kawneer does not control the selection of product configurations, operating hardware, or glazing materials, and assumes no responsibility therefor.

Kawneer reserves the right to change configuration without prior notice when deemed necessary for product improvement.
© Kawneer Company, Inc., 2013

WIND LOAD CHARTS

Mullions are designed for deflection limitations in accordance with AAMA TIR-A11 of L/175 up to 13'-6" and L/240 +1/4" above 13'-6". These curves are for mullions WITH HORIZONTALS and are based on engineering calculations for stress and deflection. Allowable wind load stress for ALUMINUM 15,152 psi (104 MPa), STEEL 30,000 psi (207 MPa). Charted curves, in all cases are for the limiting value. Wind load charts contained herein are based upon nominal wind load utilized in allowable stress design. A conversion from Load Resistance Factor Design (LRFD) is provided. To convert ultimate wind loads to nominal loads, multiply ultimate wind loads by a factor of 0.6 per ASCE/SEI 7. A 4/3 increase in allowable stress has not been used to develop these curves. For special situations not covered by these curves, contact your Kawneer representative for additional information.

DEADLOAD CHARTS

Horizontal or deadload limitations are based upon 1/8" (3.2) maximum deflection at the center of an intermediate horizontal member. The accompanying charts are calculated for 1/4" (6.4) and 1" (25.4) thick glass supported on two setting blocks placed at the loading points shown.

Laws and building and safety codes governing the design and use of glazed entrance, window, and curtain wall products vary widely. Kawneer does not control the selection of product configurations, operating hardware, or glazing materials, and assumes no responsibility therefor.

Kawneer reserves the right to change configuration without prior notice when deemed necessary for product improvement.
© Kawneer Company, Inc., 2013

	Allowable Stress Design Load	LRFD Ultimate Design Load
A =	20 PSF (960)	33 PSF (1580)
B =	30 PSF (1440)	50 PSF (2400)
C =	40 PSF (1920)	67 PSF (3200)
D =	50 PSF (2400)	83 PSF (4000)
E =	60 PSF (2880)	100 PSF (4790)

WITH HORIZONTALS

METERS

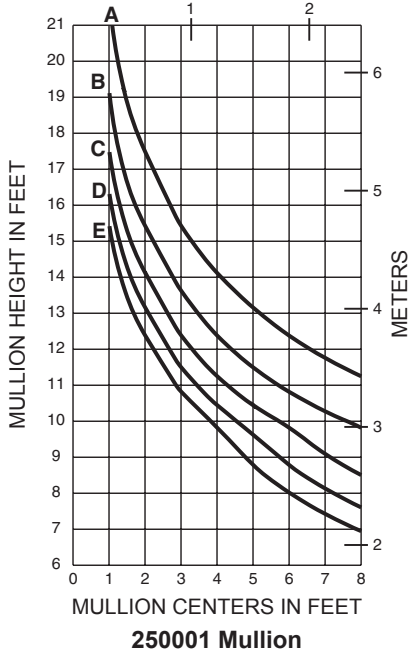

WITH HORIZONTALS

METERS

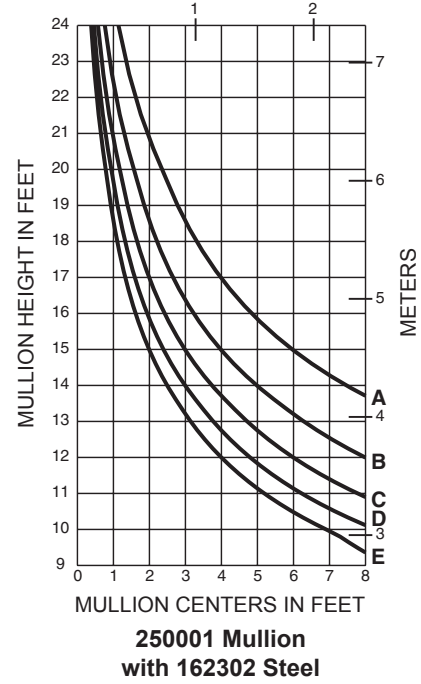

WITH HORIZONTALS

METERS

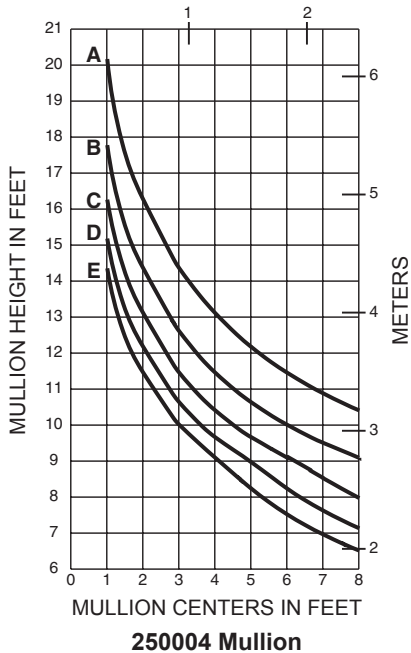

WITH HORIZONTALS

METERS

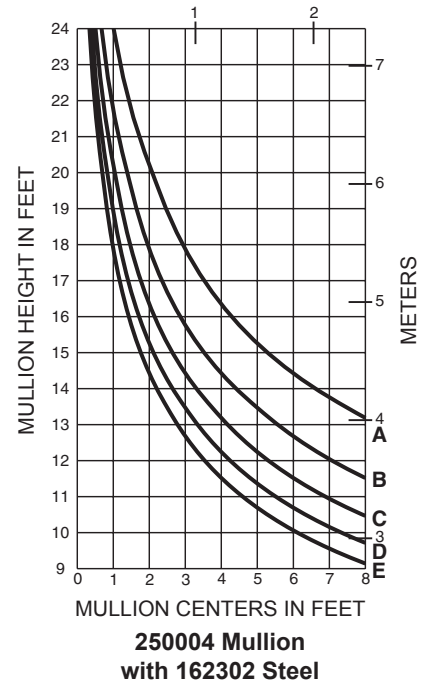

Laws and building and safety codes governing the design and use of glazed entrance, window, and curtain wall products vary widely. Kawneer does not control the selection of product configurations, operating hardware, or glazing materials, and assumes no responsibility therefor.

Kawneer reserves the right to change configuration without prior notice when deemed necessary for product improvement.
 © Kawneer Company, Inc., 2013

	Allowable Stress Design Load	LRFD Ultimate Design Load
A =	20 PSF (960)	33 PSF (1580)
B =	30 PSF (1440)	50 PSF (2400)
C =	40 PSF (1920)	67 PSF (3200)
D =	50 PSF (2400)	83 PSF (4000)
E =	60 PSF (2880)	100 PSF (4790)

WITH HORIZONTALS

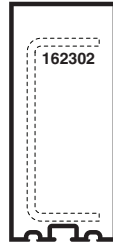
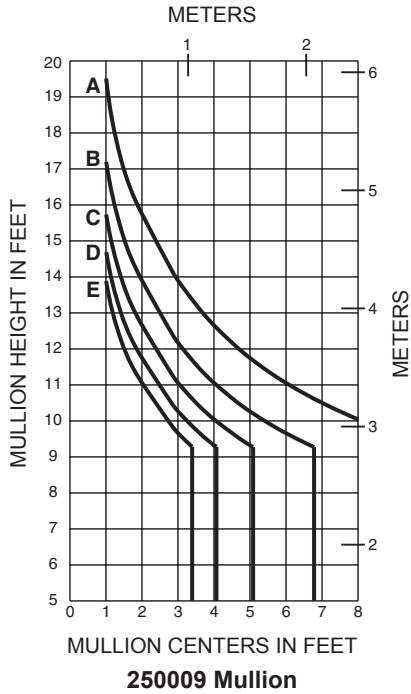

250009

I = 5.310 (221.0 x 10⁶)
S = 2.044 (33.5 x 10³)

162302 Steel

I = 2.111 (87.9 x 10⁶)
S = 1.108 (18.2 x 10³)

WITH HORIZONTALS

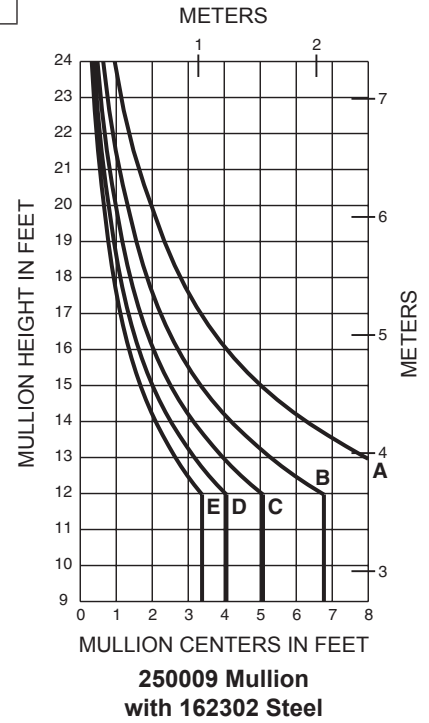

WITH HORIZONTALS

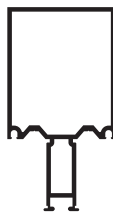
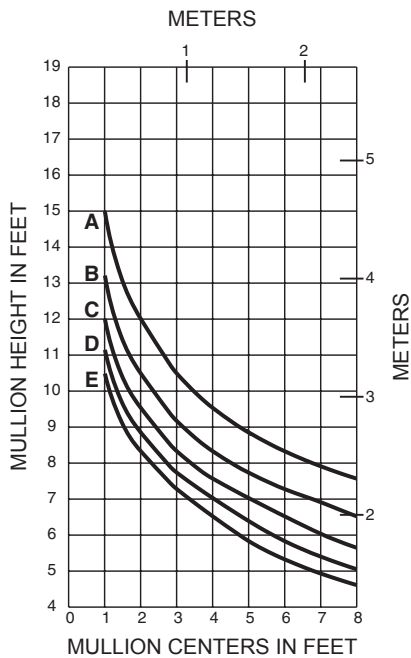

250011

I = 2.271 (94.5 x 10⁶)
S = 1.007 (16.5 x 10³)

WITHOUT HORIZONTALS

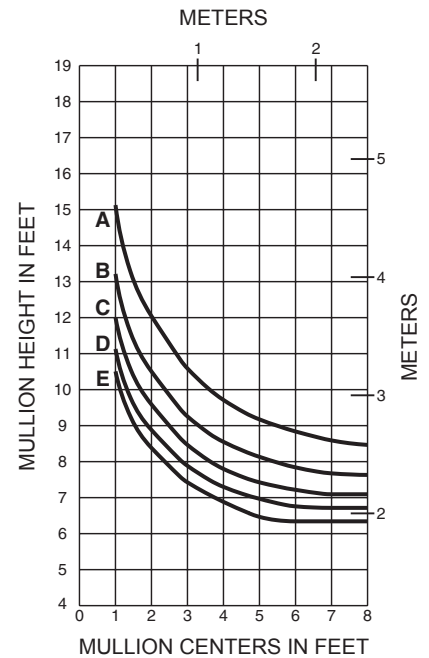

Laws and building and safety codes governing the design and use of glazed entrance, window, and curtain wall products vary widely. Kawneer does not control the selection of product configurations, operating hardware, or glazing materials, and assumes no responsibility therefor.

Kawneer reserves the right to change configuration without prior notice when deemed necessary for product improvement.
© Kawneer Company, Inc., 2013

	Allowable Stress Design Load	LRFD Ultimate Design Load
A =	20 PSF (960)	33 PSF (1580)
B =	30 PSF (1440)	50 PSF (2400)
C =	40 PSF (1920)	67 PSF (3200)
D =	50 PSF (2400)	83 PSF (4000)
E =	60 PSF (2880)	100 PSF (4790)

WITH HORIZONTALS

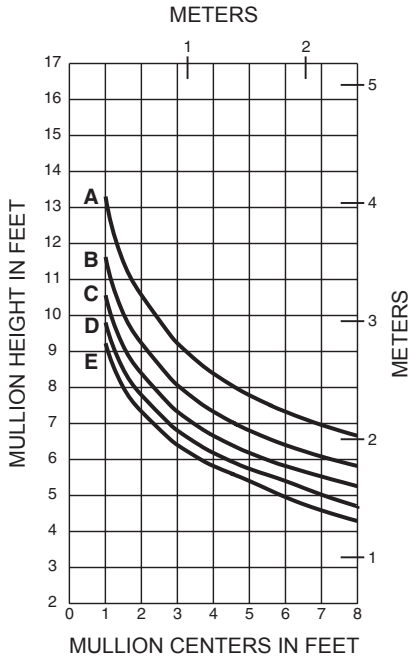

WITHOUT HORIZONTALS

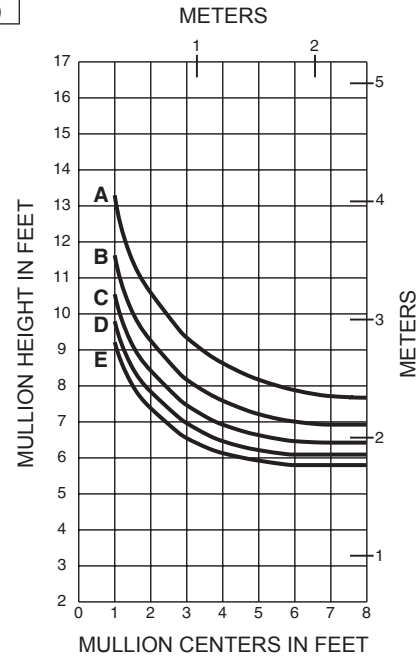

WITH HORIZONTALS

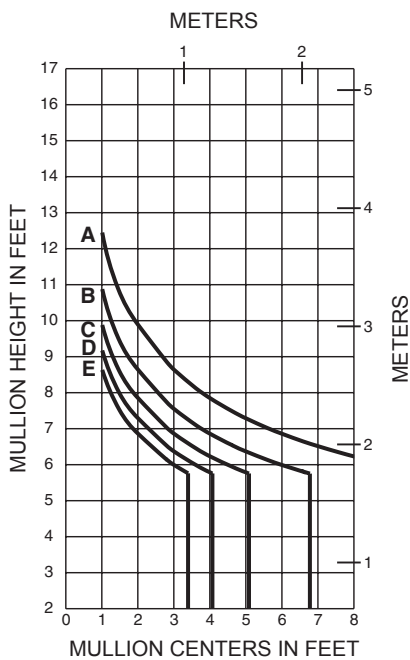

WITHOUT HORIZONTALS

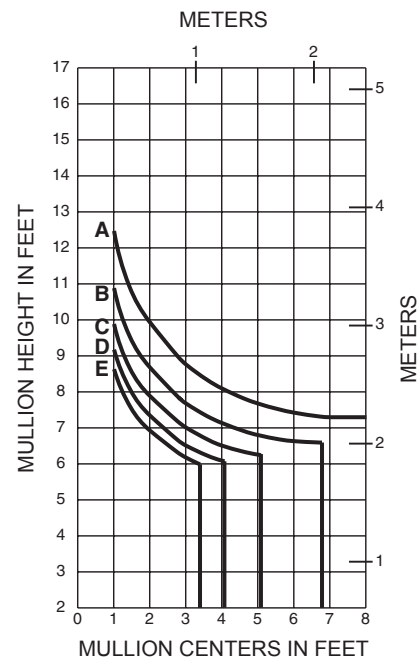

Laws and building and safety codes governing the design and use of glazed entrance, window, and curtain wall products vary widely. Kawneer does not control the selection of product configurations, operating hardware, or glazing materials, and assumes no responsibility therefor.

Kawneer reserves the right to change configuration without prior notice when deemed necessary for product improvement.
 © Kawneer Company, Inc., 2013

A = 1/4 POINT LOADING
B = 1/8 POINT LOADING

1" GLASS

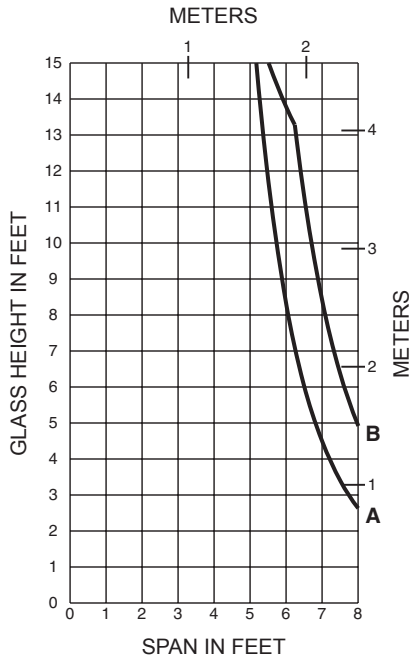

250001

I = 1.282 (53.3 x 10⁴)
S = 1.140 (18.6 x 10³)



250004

I = 1.274 (53.0 x 10⁴)
S = 1.132 (18.6 x 10³)

1/4" GLASS

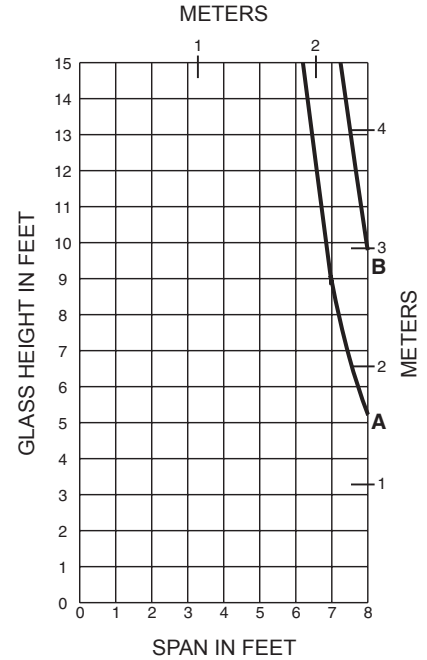

1" GLASS

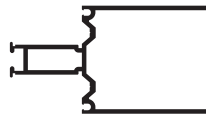
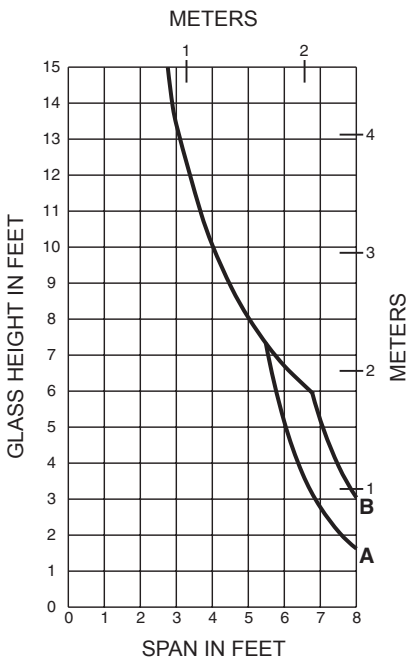

250011

I = 0.791 (32.9 x 10⁴)
S = 0.703 (11.5 x 10³)

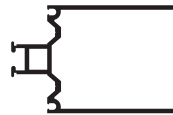

250014

I = 0.781 (20.9 x 10⁴)
S = 0.694 (11.4 x 10³)

1/4" GLASS

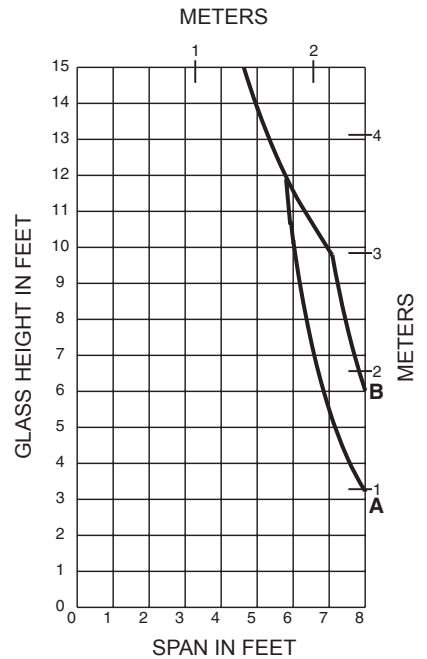

Laws and building and safety codes governing the design and use of glazed entrance, window, and curtain wall products vary widely. Kawneer does not control the selection of product configurations, operating hardware, or glazing materials, and assumes no responsibility therefor.

Kawneer reserves the right to change configuration without prior notice when deemed necessary for product improvement.
© Kawneer Company, Inc., 2013

A = 1/4 POINT LOADING

B = 1/8 POINT LOADING

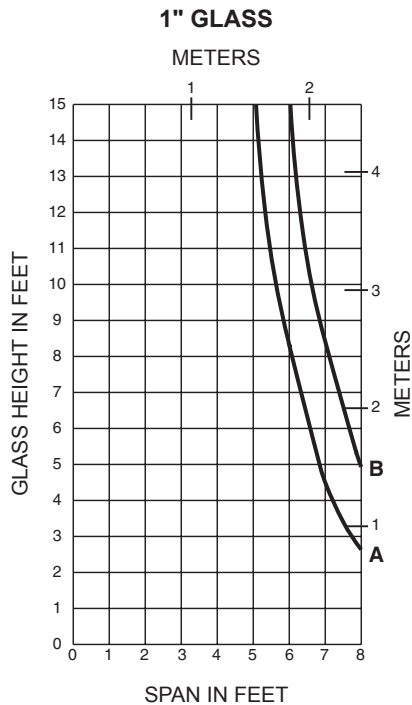
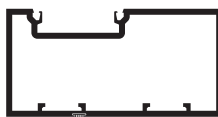
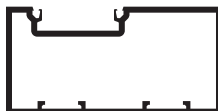
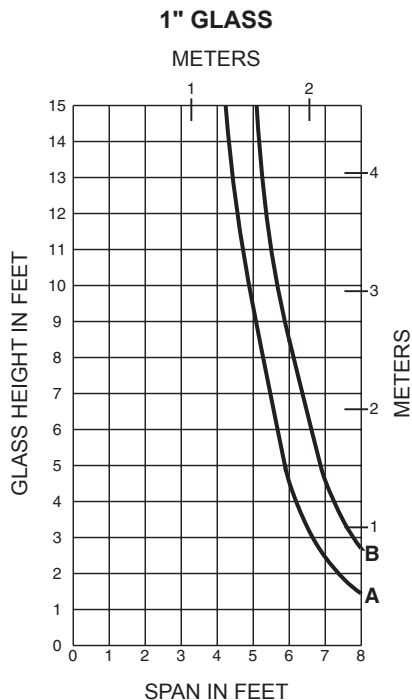

Laws and building and safety codes governing the design and use of glazed entrance, window, and curtain wall products vary widely. Kawneer does not control the selection of product configurations, operating hardware, or glazing materials, and assumes no responsibility therefor.

Kawneer reserves the right to change configuration without prior notice when deemed necessary for product improvement.
© Kawneer Company, Inc., 2013

**Project Specific U-Factor
Example Calculation**
(Based on single bay of Curtain Wall/Window Wall)

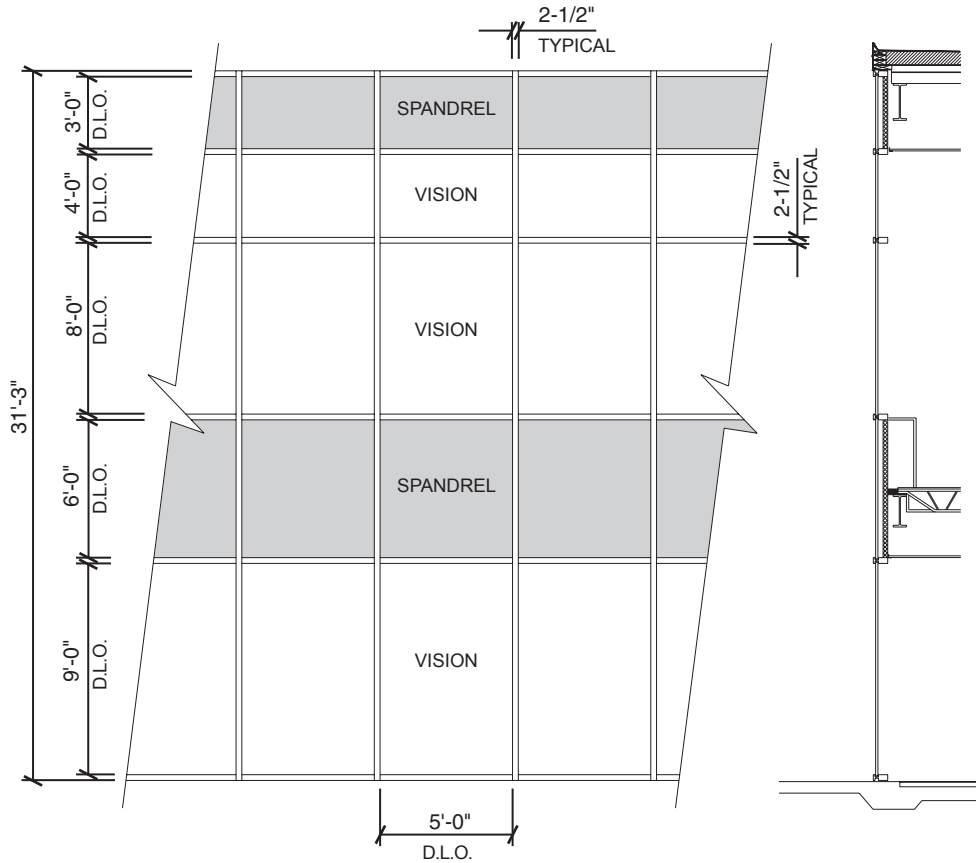

Vision Area

Example Glass U-Factor = 0.48 Btu/(ft² x h x °F)

Vision Area = 5(9 + 8 + 4) = 105.0 ft

Total Area (Vision) = 5' 2-1/2"(9' 3-3/4" + 8' 2-1/2" + 4' 2-1/2") = 113.2 ft

Percent of Vision Glass = (Vision Area ÷ Total Area)100
= (105.0 ÷ 113.2)100 = 93%

Spandrel Area

Example Spandrel R-value = 15(ft² x h x °F)/Btu

Spandrel Area = 5(6 + 3) = 45.0 ft

Total Area Spandrel = 5' 2-1/2"(6' 2-1/2" + 3' 3-3/4") = 49.6 ft

Percent of Spandrel = (Spandrel Area ÷ Total Area)100
= (45.0 ÷ 49.6)100 = 91%

Laws and building and safety codes governing the design and use of glazed entrance, window, and curtain wall products vary widely. Kawneer does not control the selection of product configurations, operating hardware, or glazing materials, and assumes no responsibility therefor.

Kawneer reserves the right to change configuration without prior notice when deemed necessary for product improvement.
© Kawneer Company, Inc., 2013

Vision Area Chart

System U-factor vs Percent of Vision Area

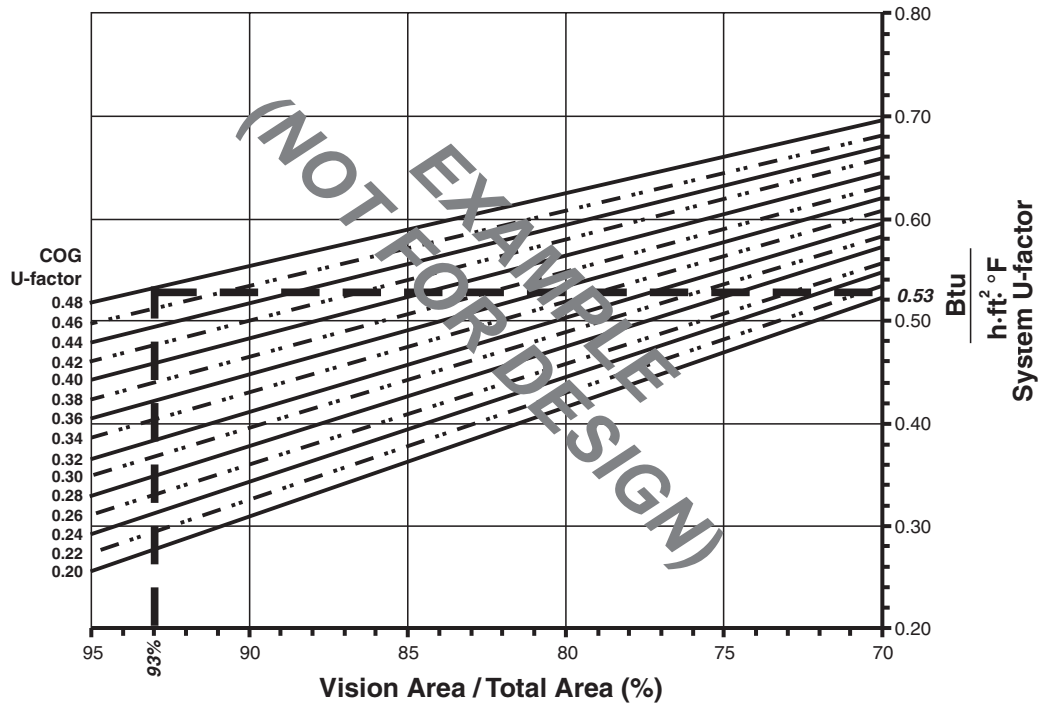

Based on a single curtain wall bay of 93% vision glass and center of glass U-factor of 0.48, System U-factor is equal to 0.53 Btu/(h-ft² · °F)

Spandrel Area Chart

System U-factor vs Percent of Spandrel Area

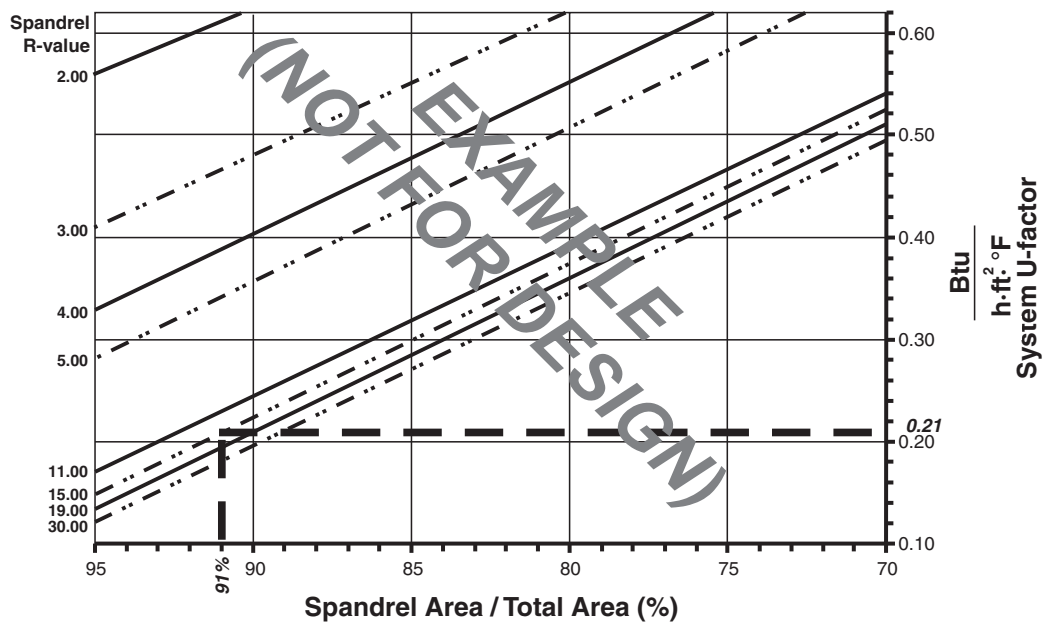

Based on a single curtain wall bay of 91% spandrel and center of spandrel R-value of 15, system U-factor is equal to 0.21 Btu/(h-ft² · °F)

Laws and building and safety codes governing the design and use of glazed entrance, window, and curtain wall products vary widely. Kawneer does not control the selection of product configurations, operating hardware, or glazing materials, and assumes no responsibility therefor.

Kawneer reserves the right to change configuration without prior notice when deemed necessary for product improvement.
© Kawneer Company, Inc., 2013

Note:
 Values in parentheses are metric.
 COG = Center Of Glass.
 Charts are generated per AAMA 507.

System U-Factors for Vision Glass

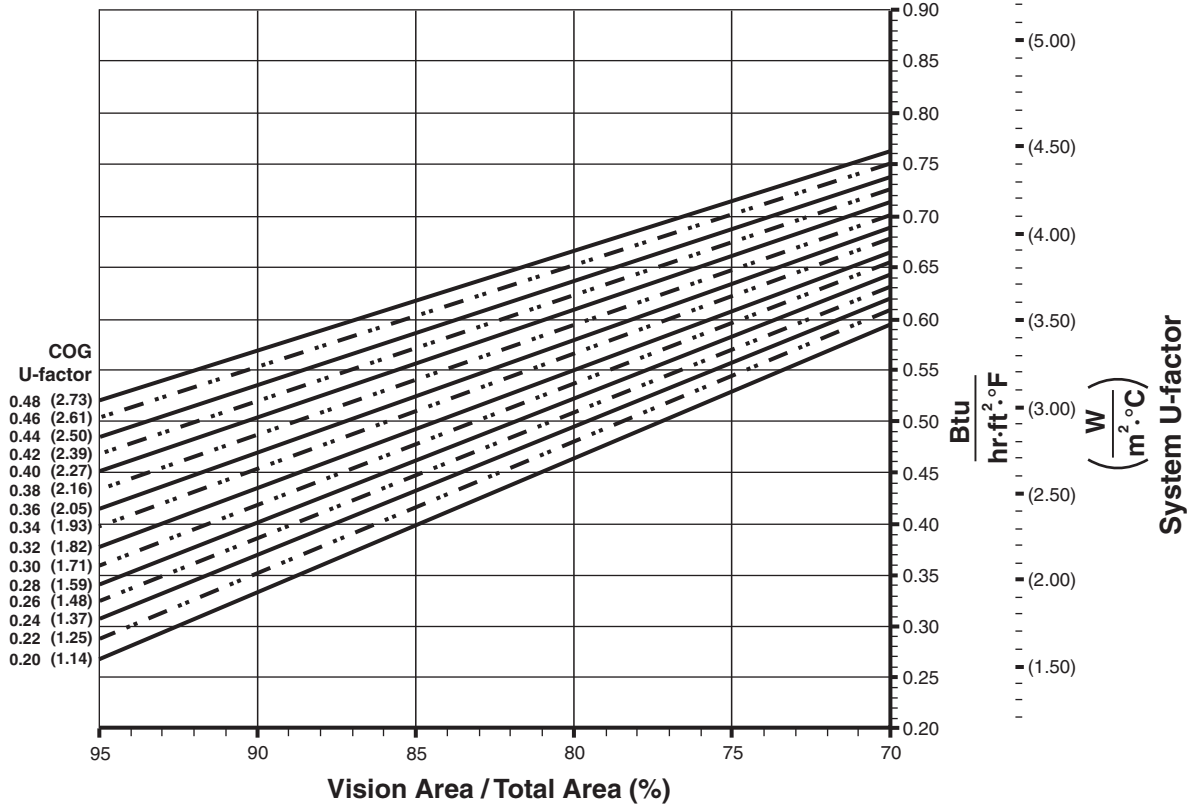

System U-Factors for Spandrel Glass

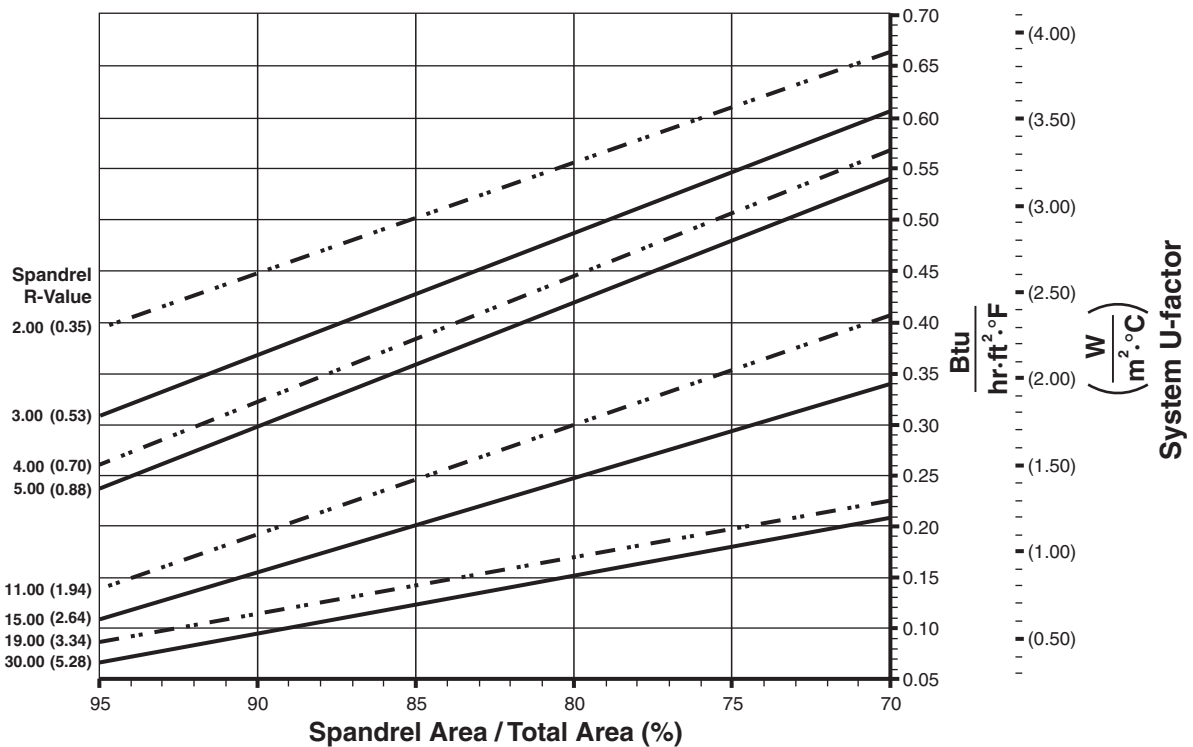

Laws and building and safety codes governing the design and use of glazed entrance, window, and curtain wall products vary widely. Kawneer does not control the selection of product configurations, operating hardware, or glazing materials, and assumes no responsibility therefor.

Kawneer reserves the right to change configuration without prior notice when deemed necessary for product improvement.
 © Kawneer Company, Inc., 2013

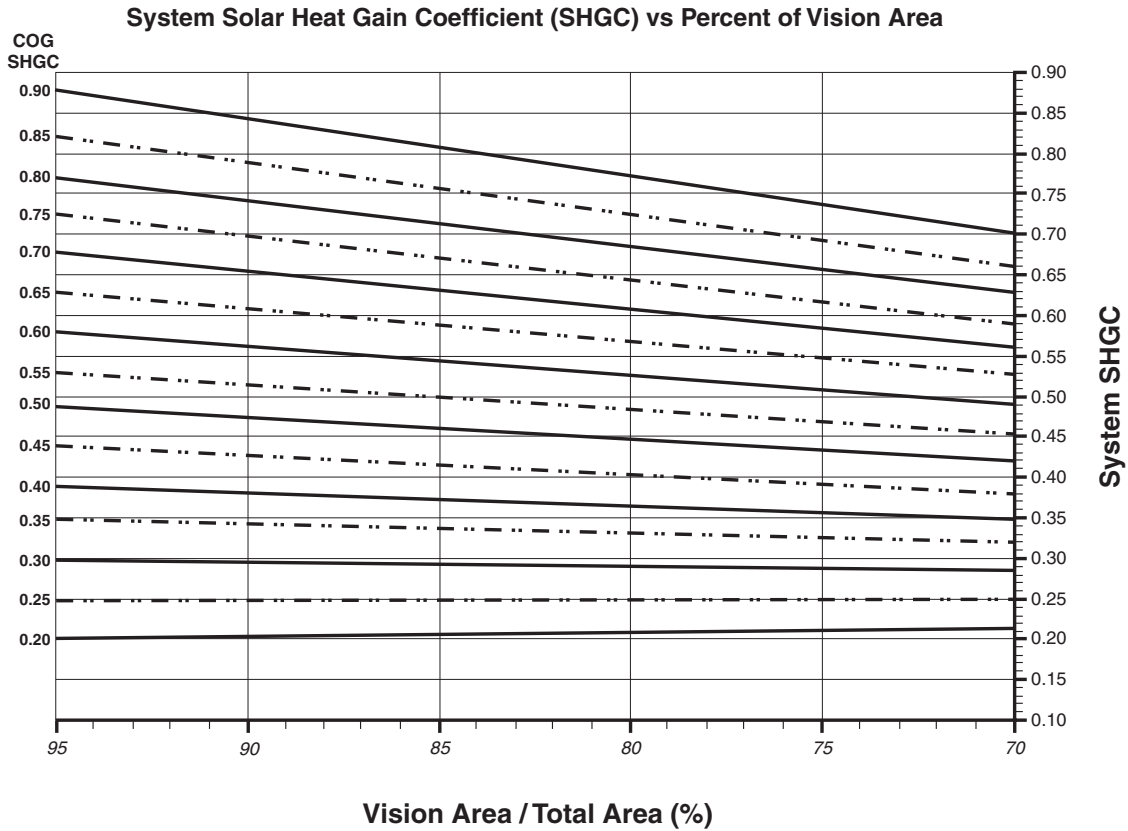

Charts are generated per AAMA 507.

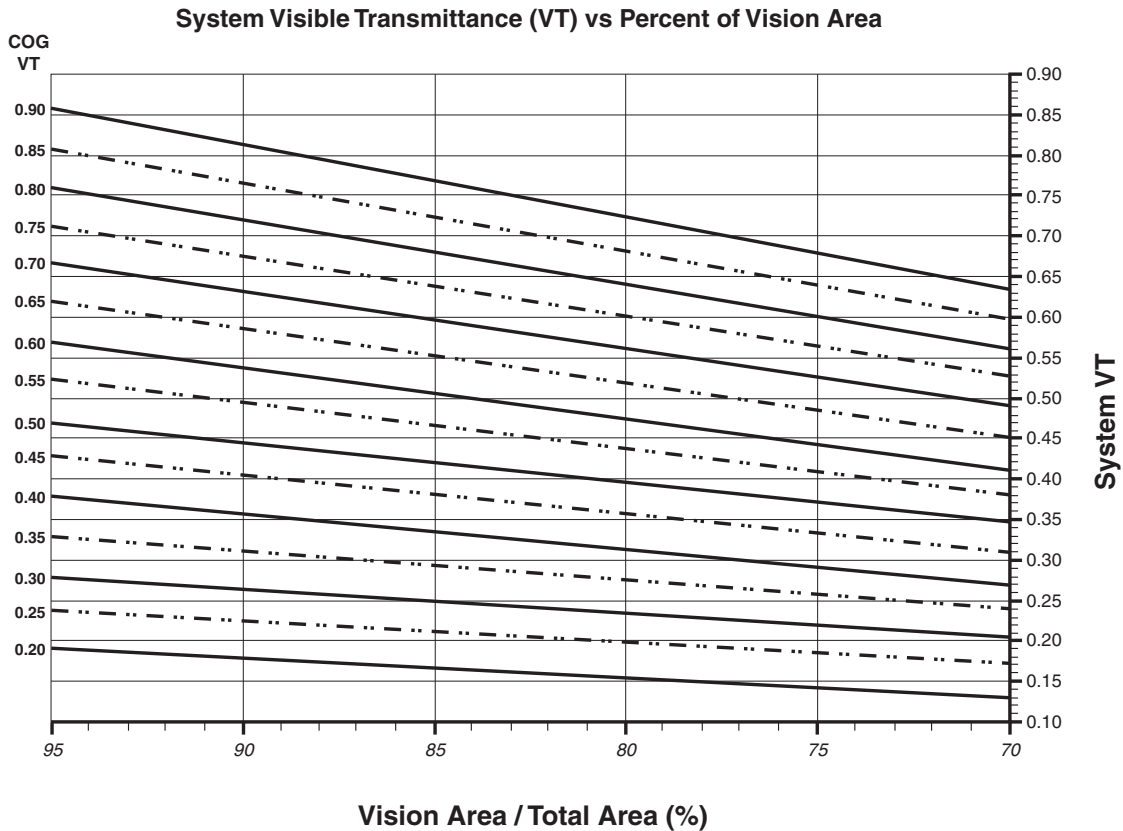

Charts are generated per AAMA 507.

Laws and building and safety codes governing the design and use of glazed entrance, window, and curtain wall products vary widely. Kawneer does not control the selection of product configurations, operating hardware, or glazing materials, and assumes no responsibility therefor.

Kawneer reserves the right to change configuration without prior notice when deemed necessary for product improvement.
© Kawneer Company, Inc., 2013

Thermal Transmittance¹ (BTU/hr • ft² • °F)

Glass U-Factor ³	Overall U-Factor ⁴
0.48	0.57
0.46	0.55
0.44	0.53
0.42	0.51
0.40	0.50
0.38	0.48
0.36	0.46
0.34	0.44
0.32	0.43
0.30	0.41
0.28	0.39
0.26	0.38
0.24	0.36
0.22	0.34
0.20	0.32

FACTORS FOR CAPTURED MULLIONS

NOTE: For glass values that are not listed, linear interpolation is permitted.

1. U-Factors are determined in accordance with NFRC 100.
2. SHGC and VT values are determined in accordance with NFRC 200.
3. Glass properties are based on center of glass values and are obtained from your glass supplier.
4. Overall U-Factor, SHGC, and VT Matricies are based on the standard NFRC specimen size of 2,000 mm wide by 2,000 mm high (78-3/4" by 78-3/4").

SHGC Matrix²

Glass SHGC ³	Overall SHGC ⁴
0.75	0.70
0.70	0.66
0.65	0.61
0.60	0.57
0.55	0.52
0.50	0.48
0.45	0.43
0.40	0.38
0.35	0.34
0.30	0.29
0.25	0.25
0.20	0.20
0.15	0.16
0.10	0.11
0.05	0.07

Visible Transmittance²

Glass VT ³	Overall VT ⁴
0.90	0.82
0.85	0.77
0.80	0.73
0.75	0.68
0.70	0.64
0.65	0.59
0.60	0.55
0.55	0.50
0.50	0.45
0.45	0.41
0.40	0.36
0.35	0.32
0.30	0.27
0.25	0.23
0.20	0.18

Laws and building and safety codes governing the design and use of glazed entrance, window, and curtain wall products vary widely. Kawneer does not control the selection of product configurations, operating hardware, or glazing materials, and assumes no responsibility therefor.

Kawneer reserves the right to change configuration without prior notice when deemed necessary for product improvement.
© Kawneer Company, Inc., 2013

Note:
 Values in parentheses are metric.
 COG = Center Of Glass.
 Charts are generated per AAMA 507.

System U-Factors for SSG Vision Glass

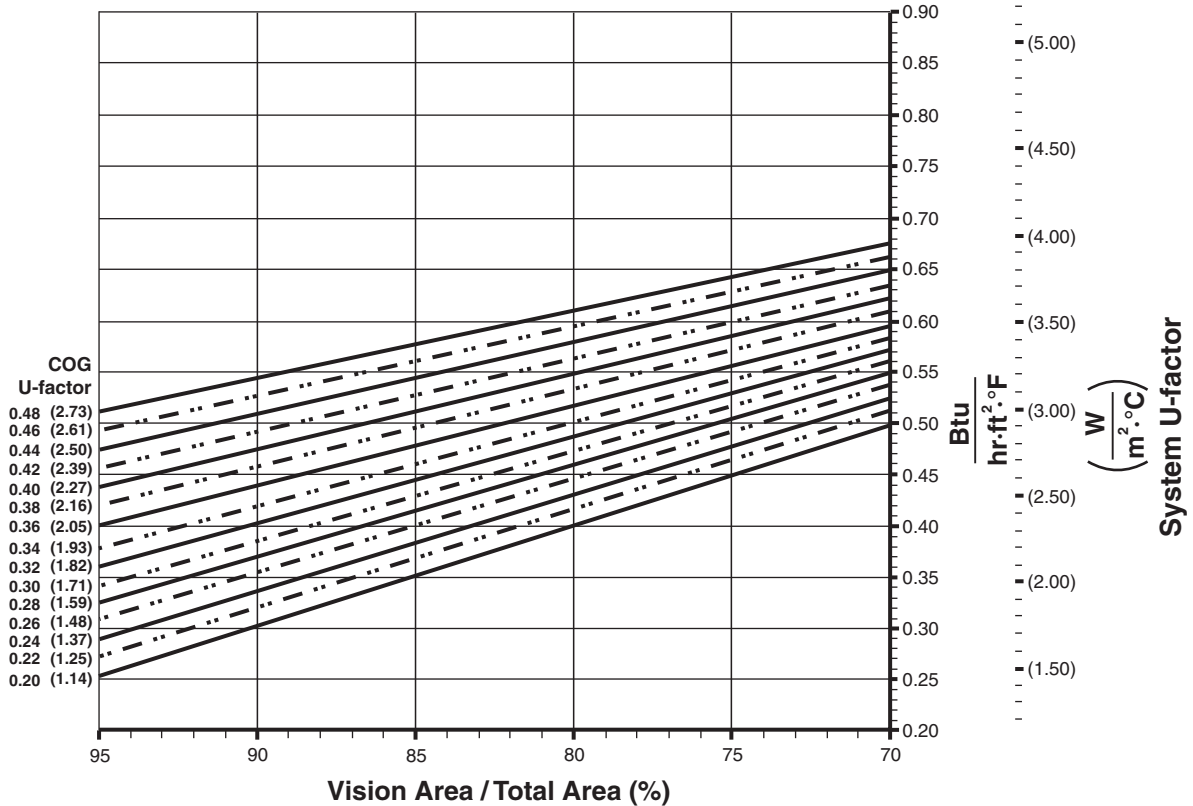

System U-Factors for SSG Spandrel Glass

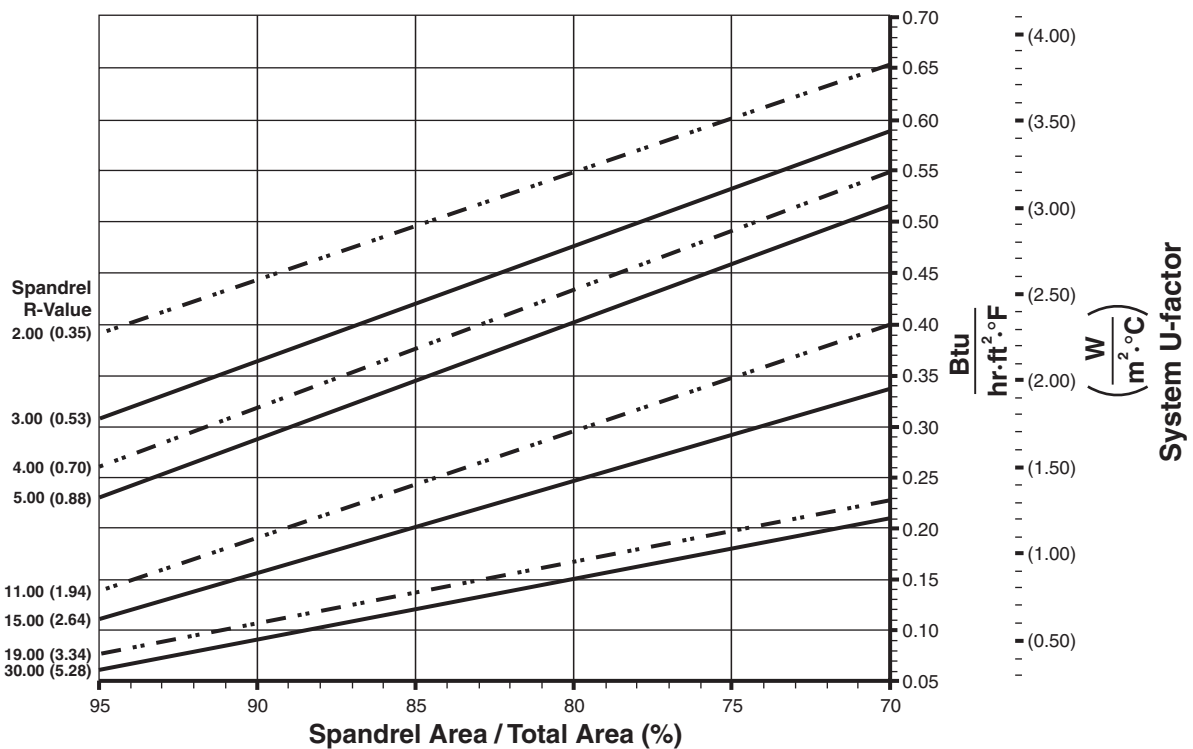

Laws and building and safety codes governing the design and use of glazed entrance, window, and curtain wall products vary widely. Kawneer does not control the selection of product configurations, operating hardware, or glazing materials, and assumes no responsibility therefor.

Kawneer reserves the right to change configuration without prior notice when deemed necessary for product improvement.
 © Kawneer Company, Inc., 2013

System Solar Heat Gain Coefficient (SHGC) vs Percent of SSG Vision Area

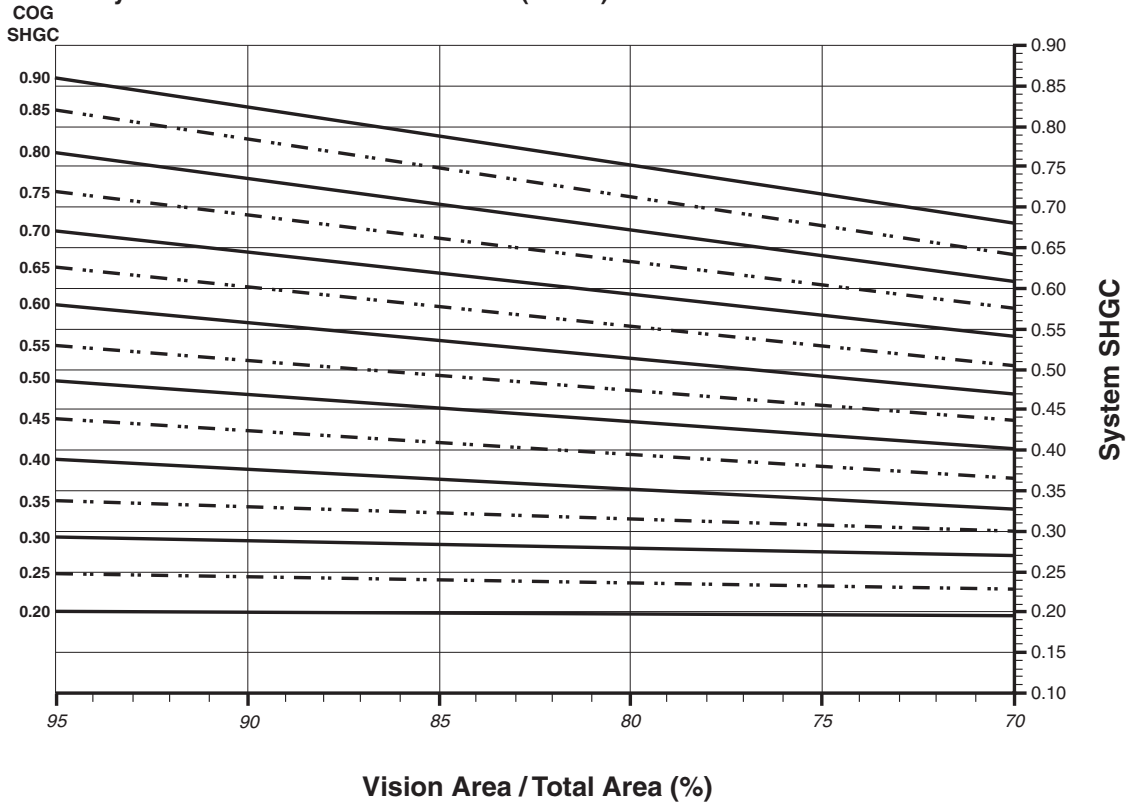

Charts are generated per AAMA 507.

System Visible Transmittance (VT) vs Percent of SSG Vision Area

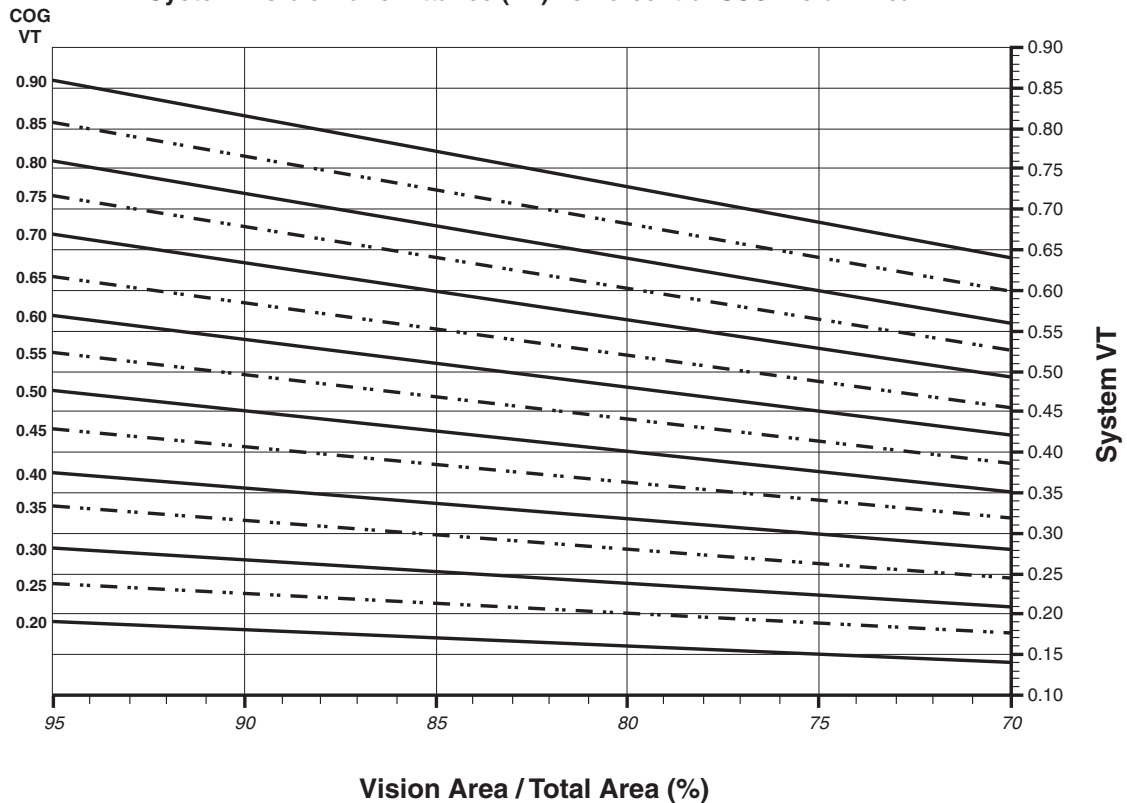

Charts are generated per AAMA 507.

Laws and building and safety codes governing the design and use of glazed entrance, window, and curtain wall products vary widely. Kawneer does not control the selection of product configurations, operating hardware, or glazing materials, and assumes no responsibility therefor.

Kawneer reserves the right to change configuration without prior notice when deemed necessary for product improvement.
© Kawneer Company, Inc., 2013

Thermal Transmittance¹ (BTU/hr • ft² • °F)

Glass U-Factor ³	Overall U-Factor ⁴
0.48	0.54
0.46	0.52
0.44	0.50
0.42	0.48
0.40	0.46
0.38	0.45
0.36	0.43
0.34	0.41
0.32	0.39
0.30	0.38
0.28	0.36
0.26	0.34
0.24	0.32
0.22	0.30
0.20	0.29

FACTORS FOR SSG MULLIONS

NOTE: For glass values that are not listed, linear interpolation is permitted.

1. U-Factors are determined in accordance with NFRC 100.
2. SHGC and VT values are determined in accordance with NFRC 200.
3. Glass properties are based on center of glass values and are obtained from your glass supplier.
4. Overall U-Factor, SHGC, and VT Matricies are based on the standard NFRC specimen size of 2,000 mm wide by 2,000 mm high (78-3/4" by 78-3/4").

SHGC Matrix²

Glass SHGC ³	Overall SHGC ⁴
0.75	0.70
0.70	0.65
0.65	0.61
0.60	0.56
0.55	0.52
0.50	0.47
0.45	0.43
0.40	0.38
0.35	0.33
0.30	0.29
0.25	0.24
0.20	0.20
0.15	0.15
0.10	0.11
0.05	0.06

Visible Transmittance²

Glass VT ³	Overall VT ⁴
0.90	0.82
0.85	0.78
0.80	0.73
0.75	0.69
0.70	0.64
0.65	0.59
0.60	0.55
0.55	0.50
0.50	0.46
0.45	0.41
0.40	0.37
0.35	0.32
0.30	0.27
0.25	0.23
0.20	0.18

Laws and building and safety codes governing the design and use of glazed entrance, window, and curtain wall products vary widely. Kawneer does not control the selection of product configurations, operating hardware, or glazing materials, and assumes no responsibility therefor.

Kawneer reserves the right to change configuration without prior notice when deemed necessary for product improvement.
© Kawneer Company, Inc., 2013