

WHITE PAPER

WARM-EDGE SPACER

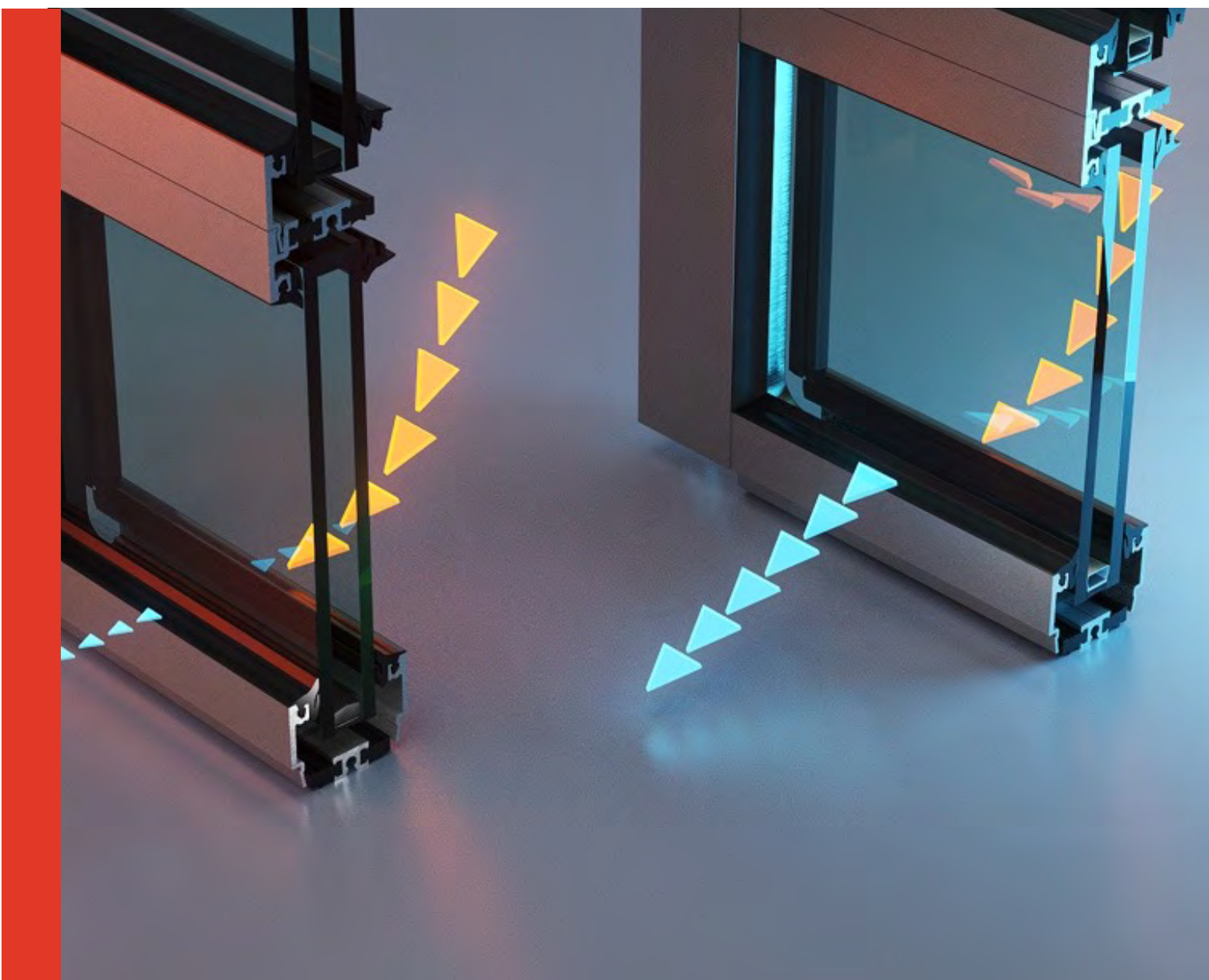



MORE COMPLIANCE IN MORE CLIMATE ZONES

Achieving higher thermal performance with warm-edge spacers

Architects and designers are constantly challenged to reduce building energy intensity by improving the fenestration performance, while keeping up with ever-changing energy codes for glazed building envelope products.

To tackle this, common solutions are either a more insulating framing system (new/different product system) or triple glazing options. Both options have a significant impact on budget and require the advanced technical expertise needed for assembling and glazing installation.

However, there is an often-neglected lever that helps improve the overall U-factor (thermal resistance) performance of a framing system with the same glazing package by up to 15%.

THE SELECTION OF THE GLAZING SPACER SYSTEM.

Without changing the framing system and glass package, simply switching from an aluminum spacer to a warm-edge spacer could reduce the U-factor significantly, improve condensation resistance and potentially help to meet project requirements, without incremental cost.

To assist architects and designers in understanding the product thermal performance with warm-edge spacers, Kawneer is updating its product literature with warm-edge spacer thermal data, starting with Curtain Wall and Window Wall products.

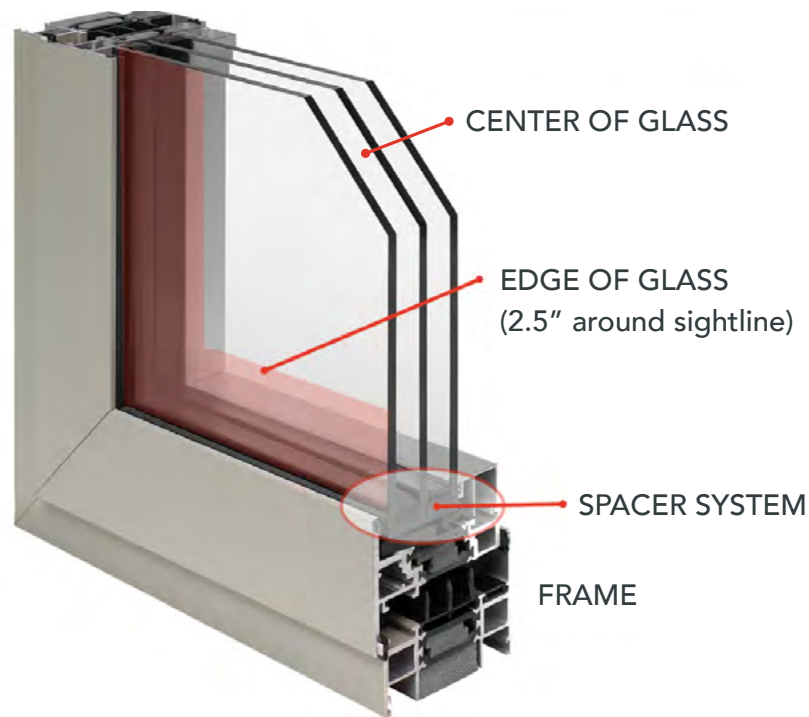

U-FACTOR AND RELATIONSHIP WITH SPACER SYSTEM:

Overall product U-factor is determined by the area weighted average of the heat transfer across three regions of the product: frame, center of glass and edge of glass performances – as per NFRC 100 method*. The lower the U-factor number, the more insulating the product performance. Hence, lower U-factor values are desirable.

As per the industry standard rule, the glazing area 2.5" from the sightline is considered 'edge of glass'. Edge of glass thermal transmittance is heavily influenced by the type of spacer system, and it has a significant impact on the overall product performance.

As expected, an aluminum spacer would conduct more heat, and have higher thermal transmittance compared to a lower conducting polymer or composite edge system.

$$U - \text{Factor (Overall)} = \frac{U_{COG} * A_{COG} + U_{Frame} * A_{Frame} + U_{Edge} * A_{Edge}}{A_{COG} + A_{Frame} + A_{Edge}}$$

Keep in mind, that building energy codes specify compliance targets for the overall product or system's thermal performance, not individual components, for example center of glass, or spacer type.

Kawneer provides overall system performance for different center of glass U-factor values and has thermal performance data for both aluminum and warm-edge spacers**, as shown on page 4 in an extract from the published thermal chart for the 2500 UT Unitwall® System.

*ANSI/NFRC 100-2020 [E0A0]: Procedure for Determining Fenestration Product U-factors may be obtained from <https://nfrccommunity.org/>

**Effective thermal conductivity (K_{eff}) of the warm-edge spacer assembly used in calculation of overall system U-factor shown throughout this document is 0.28 W/m.K (0.16 Btu/hr.ft.F). The overall system U-factors using warm-edge spacers with other K_{eff} may differ from those shown.

IMPACT OF WARM-EDGE SPACER ON OVERALL U-FACTOR

Lower U-factor number is better performance

Table: U-factor (Btu/hr-ft²-°F) impact with spacer selection on 2500 UT Unitwall® System – SGT (Captured version).

GLASS	ALUMINIUM SPACER	WARM-EDGE SPACER*
COG U-FACTOR	SYSTEM OVERALL U-FACTOR	SYSTEM OVERALL U-FACTOR
0.28	0.37	0.33
0.24	0.34	0.30
0.20	0.30	0.26

Δ 12% IMPROVEMENT

HIGHER THERMAL PERFORMANCE

As you can see, for a common double-glazed (low-emissivity coating and argon gas-filled) system with a center of glass U-factor of 0.24 Btu/hr-ft²-°F, the overall product U-factor improved from 0.34 to 0.30 Btu/hr-ft²-°F or by ~12%, just by selecting the warm-edge spacer.

It makes a significant difference in allowing projects to meet higher thermal performance requirements, using the same product and glazing packages.

SIGNIFICANT IMPACT

Another noteworthy observation from the chart above is the increasingly higher impact on thermal performance from a warm-edge spacer, as the center of glass becomes more insulating (e.g. at lower U-factors).

Given the overall industry trend of using higher and higher insulating products, the warm-edge spacer impact can be significant.

CONDENSATION RESISTANCE

Additional to improving the U-factor, warm-edge spacers help improve the condensation resistance near the edge of glass area.

See the infrared temperature map of a product cross-section with the same center of glass, but with a different spacer system to visualize the impact of the spacer on the edge temperature. Edge of temperature could be up to 10°F warmer with the warm-edge spacer, hence significantly reducing chances of condensation at the intersection of frame and glazing.

EXAMPLE OF FRAME CROSS SECTION TEMPERATURES WITH ALUMINUM VS. WARM-EDGE SPACER

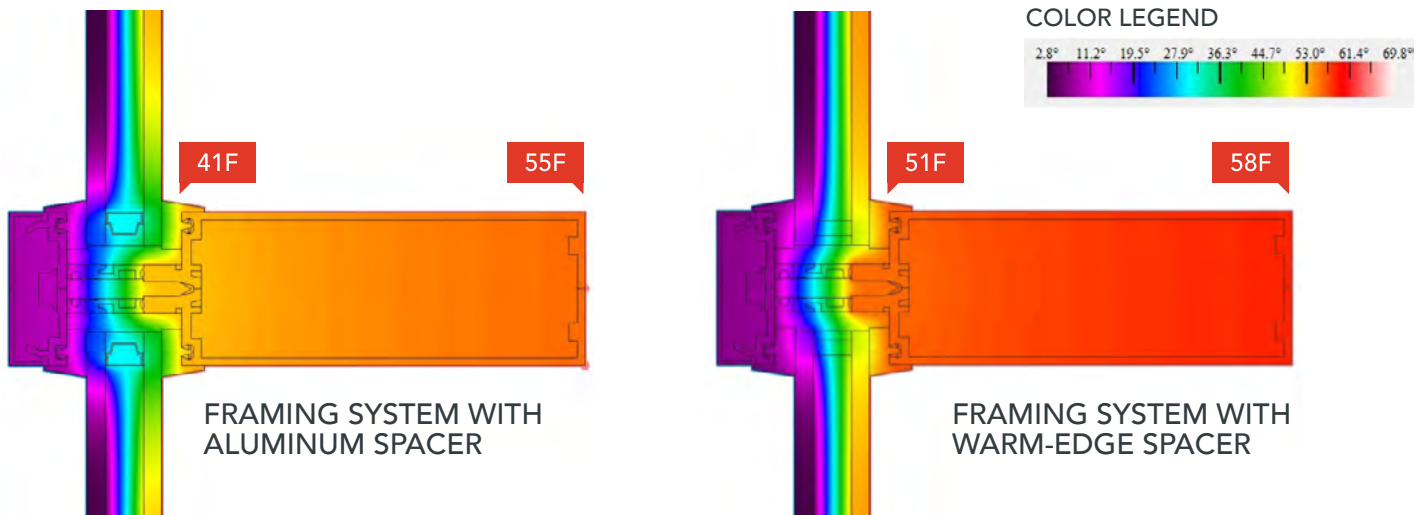

ICISS/ASHRAE 90.1
CLIMATE ZONE

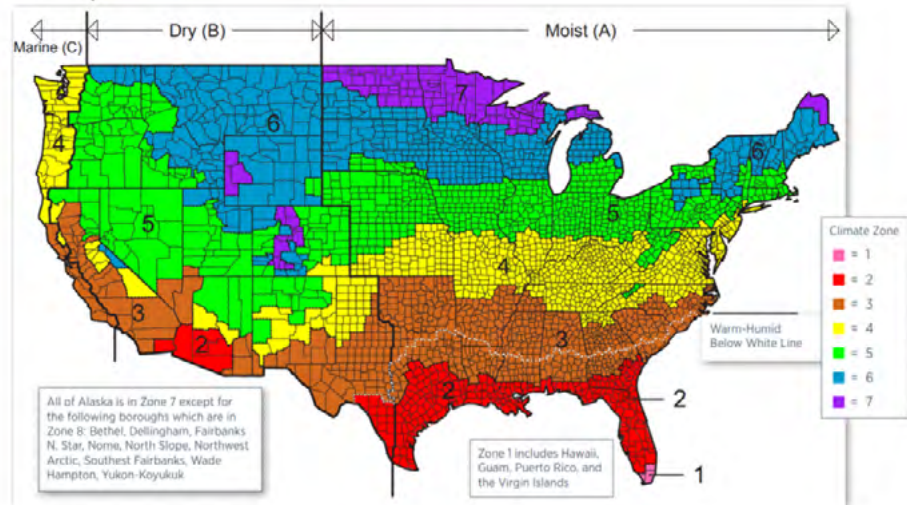

BUILDING ENERGY CODES

Looking at the IECC 2018 prescriptive code requirement for the minimum U-factor of fenestration products (fixed product type e.g., curtain wall, window wall, and operable) – an improvement in U-factor could allow products to qualify in more climate zones, with the same glazing package and selection of a warm-edge spacer.

Let’s look at the impact of selecting a warm-edge spacer with the Kawneer 1600 Wall System[®]1 Curtain Wall - which is our industry’s flag-bearer stick build curtain wall system. For a center of glass U-factor of 0.24, the overall product U-factor improves from 0.38 with an aluminum spacer, to 0.35 with the warm-edge spacer, giving ~8% improvement.

Similarly, for a 1600UT System[™]2 curtain wall system, without any framing design change and a double pane low-e and argon-filled unit (center of glass 0.24), the overall U-factor improves from 0.33 with a metal spacer, to 0.29 with an aluminum-edge spacer.

This gives a ~12% improvement which helps it to qualify for climate zone 7, without any change to the framing system or glass package, simply by selecting the warm-edge spacer.

Table: Minimum U-factor requirements for fixed (e. g., curtain wall and window wall) fenestration products per IECC 2018 and 2021.

CLIMATE ZONES	2018 IECC	2021 IECC / 90.1-2019
8	0.29	0.26
7	0.29	0.29
6	0.36	0.34
5	0.38	0.36
4	0.38	0.36
3	0.46	0.42
2	0.50	0.45
1	0.50	0.50

WARM-EDGE SPACER

ALUMINUM SPACER

ADVANCEMENTS IN GLAZING SPACER TECHNOLOGIES

Insulating glass units consist of two or more panes of glass, with a gap between them. The spacer system bonds the edges of the insulating glass unit, and helps in maintaining the gap between the panes, preventing moisture vapor and gas transmission across the glazing cavity. Spacer systems play a vital role in longevity and durability of any glazing system. Parts of a spacer system include the spacer bar (e.g., metal, thermoplastic, composite or foam), optional primary sealant (PIB), and secondary structural sealant (e.g., silicone). Thermal performance of an assembled spacer system can be defined by the effective thermal conductivity (K_{eff}) and is calculated per NFRC guidelines. Being a single number, effective thermal conductivity makes it easier for evaluating the thermal performances of difference spacer-edge assembly systems.

In commercial glazing, both aluminum and warm-edge spacers use structural silicone for the structural integrity of the glazing unit.

Since insulated glass units came on the market in the 1960s, aluminum bar spacers have been commonly used. Higher thermal conductivity of the spacer creates a thermal bridge path across the glazing panes around the edges, leading to higher heat transfer and reduced temperature on the interior surfaces, with higher chances of condensation.

A warm-edge spacer is typically referred to as the lower conducting edge bonding system, either with non-metallic, foam or composite materials. This came to market in the 1990s and usage has been increasing steadily. In recent years, growing numbers of commercial glazing fabricators have incorporated warm-edge spacer technology as part of their fabricated glazing offering.

Although Kawneer does not manufacture the glazing spacer system or provide fabricated glazing, we do provide the overall fenestration system's thermal performance data with various center of glass and spacer system types. All leading glazing fabricators have incorporated warm-edge spacer technology into their offering, and spacer manufacturers have been creating awareness in the industry about the availability and benefits of warm-edge spacers.

KAWNEER'S OFFERING

As a system manufacturer, Kawneer provides the system thermal performance data for a range of glazing options, with a U-factor from 0.48 for a simple double-glazed unit, to an advanced triple-glazed unit with a U-factor of as low as 0.10 Btu/hr-Ft²-F, along with spacer system options.

Thermal information for our products are based on the following industry standards.

PHYSICAL THERMAL TEST	THERMAL SIMULATION
✓ NFRC 102	✓ NFRC 100/200/500
✓ AAMA 1503	✓ AAMA 507
✓ ACSA A440	✓ NFRC CMA*
	✓ Manufacturer's Certificate of Compliance (CoC)

These thermal, solar, light transmittance, and condensation performances are documented in our architectural detail manual available for download on kawneer.com. In addition, Kawneer framing system components are listed in the NFRC CMA database for project specific performance calculations.*

For comparison, we show thermal performance data for our Curtain Wall and Window Wall product offerings using both warm-edge spacer and aluminum spacer options. When using warm-edge spacer technology product offerings a Center of glass (CoG) U-factor of 0.24 can be achieved with a low-e coating and argon gas fill.

*The results using CMA test methods may differ than those shown using NFRC 100 simulation procedures.



OVERALL SYSTEM U-FACTOR FOR A RANGE OF OUR PRODUCTS

The table below shows the overall U-factor for a range of our products with different assembly types, installation methods, and aesthetic looks.

Overall product U-factor value calculated with CoG 0.24 (low-e coating and argon fill) and warm-edge spacer K_{eff} of 0.28 W/m.K (0.16 Btu/hr.ft.F).

	CAPTURED		2-SIDE SSG		4-SIDE SSG	
	SYSTEM NAME	U-FACTOR	SYSTEM NAME	U-FACTOR	SYSTEM NAME	U-FACTOR
STICK BUILD	1600 System 1	0.39	1600 System 2	0.31	Clearwall SS/SB	0.30
	1600UT System 1	0.32	1600UT System 2	0.29	Clearwall SST/SSIT/SBI/SBIT	0.27
	1620UT System 1	0.32	1620UT SSG	0.29		
	7525 Wall	0.29				
SEMI-UNITIZED*	1600SS	0.39	1600SS SSG	0.31		
	1630 SS IR	0.37				
	1600 System 3	0.35				
	1600 System 4	0.33				
	2250-IG CW	0.43	2250-IG CW	0.35		
UNITIZED	2500UT-SGT	0.30	2500UT-SGT		2500UT-SGT	0.30
	2500PG	0.44	2500PG	0.34	2500PG	0.31
WINDOW WALL	Metroview FG 601T PG	0.34	Metroview FG 601T PG	0.33		
	Metroview FG 501T	0.37				
	PG123	0.32				
	FG623	0.35				

*SEMI-UNITIZED = Stick Build Screw Spline (SS), or Inside Glazed (IG) Curtain Wall.

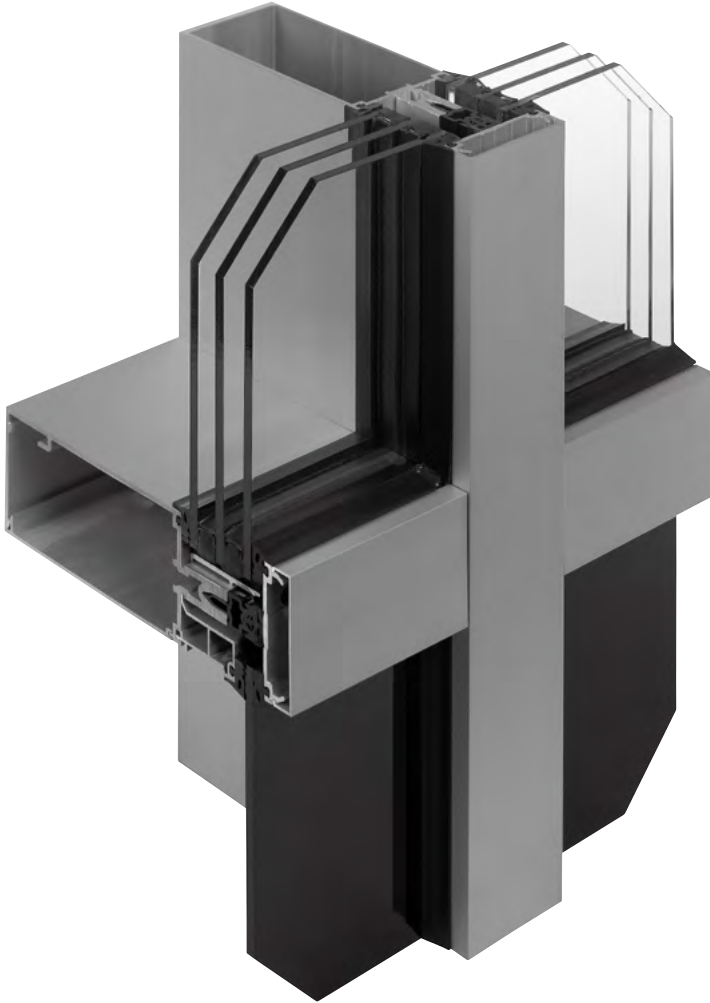

TRIPLE GLAZING CAPABILITY

For projects aiming to achieve an even higher thermal performance, we have a triple glazing capability with several of our products, for example: 1600UT System™1 and System™2 curtain wall systems.

Thermal (U-factor) information can be found in our architectural detail manual on Kawneer.com, along with solar heat gain, visual transmittance, and condensation resistance factors. Separate charts have been published for the metal (aluminum) spacer and warm-edge spacer.

These charts also allow professionals to determine product performances (U-factor, SHGC (Solar Heat Gain Coefficient), VT (Visible Transmittance)) based on the project specific sizes by utilizing glass to frame ratios.

For specific project submittals, customers can generate a manufacturer's certificate of compliance (CoC) for thermal and solar performance indices (U-factor, SHGC, VT) through Kawneer's eCommerce portal on KawneerDirect.com.

Stay tuned as we add more products with warm-edge spacer data.

SOURCES:

- https://www.energy.gov/sites/prod/files/2015/10/f27/ba_climate_region_guide_7.3.pdf
- 2018 International Energy Conservation Code - CHAPTER 4 (icc-safe.org)

BUILDING LEGACIES

Thermal performance will continue to be a trend for years to come. As market requirements shift, the need for thermal performance remains a constant. Kawneer is always pushing the envelope when it comes to delivering innovative, high-performing thermal solutions.

Our standards of success are high to ensure we meet your needs. We build on the past to advance the future to help build your legacy.

©Kawneer Company, Inc. 2021
Form No. 21-2348

Technology Park/ Atlanta
555 Guthridge Court
Norcross, GA 3009-3503

770.449.555 TEL
770.734.1560 FAX

www.kawneer.com