

WHITE PAPER

WARM-EDGE SPACER

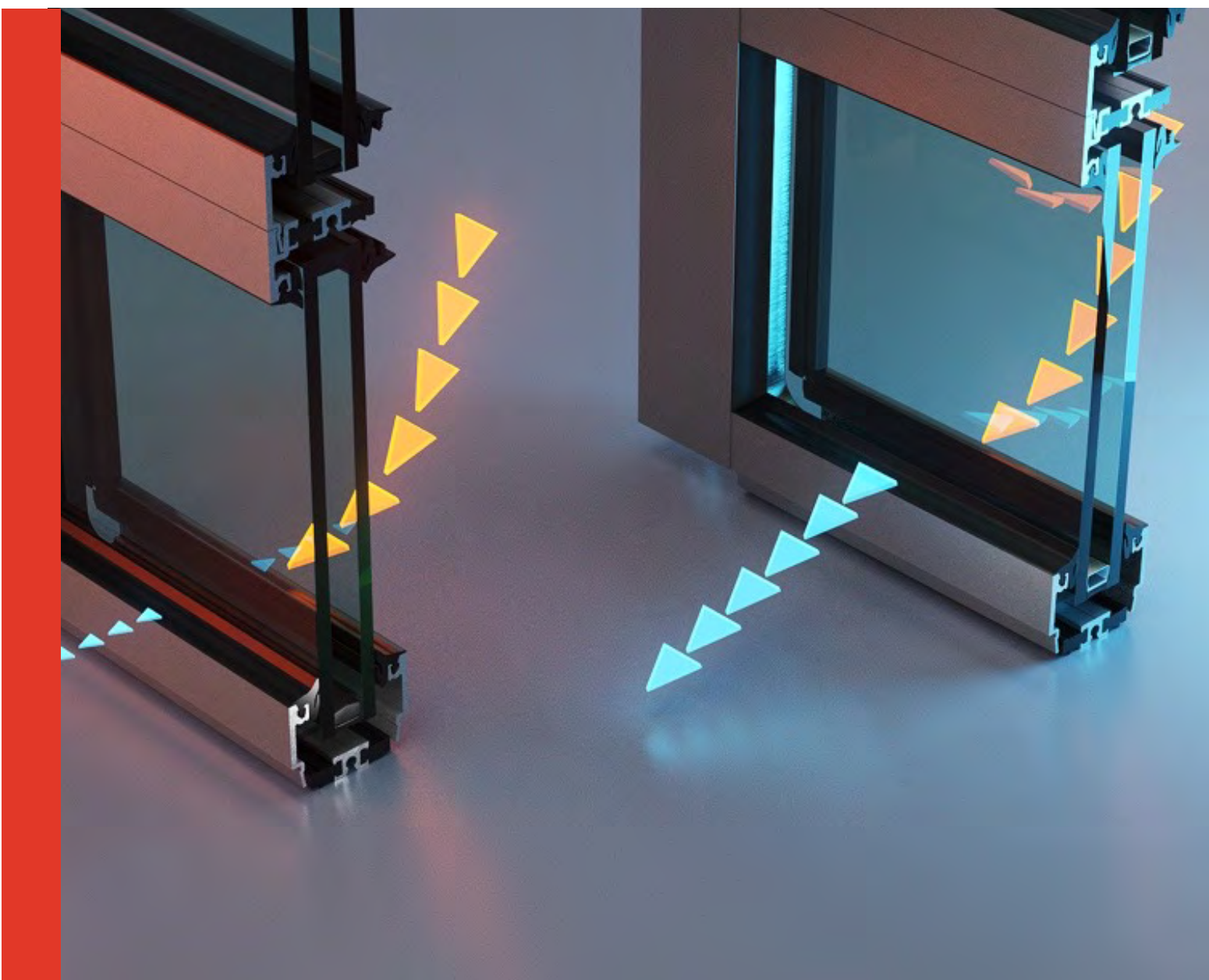



MORE COMPLIANCE IN MORE CLIMATE ZONES

Achieving higher thermal performance with warm-edge spacers

Architects and designers are constantly challenged to reduce building energy intensity by improving the fenestration performance, while keeping up with ever-changing energy codes for glazed building envelope products.

To tackle this, common solutions are either a more insulating framing system (new/different product system) or triple glazing options. Both options have a significant impact on budget and require the advanced technical expertise needed for assembling and glazing installation.

However, there is an often-neglected lever that helps improve the overall U-factor (thermal resistance) performance of a framing system with the same glazing package by up to 15%.

THE SELECTION OF THE GLAZING SPACER SYSTEM.

Without changing the framing system and glass package, simply switching from an aluminum spacer to a warm-edge spacer could reduce the U-factor significantly, improve condensation resistance and potentially help to meet project requirements, without incremental cost.

To assist architects and designers in understanding the product thermal performance with warm-edge spacers, Kawneer is updating its product literature with warm-edge spacer thermal data, starting with Curtain Wall and Window Wall products.

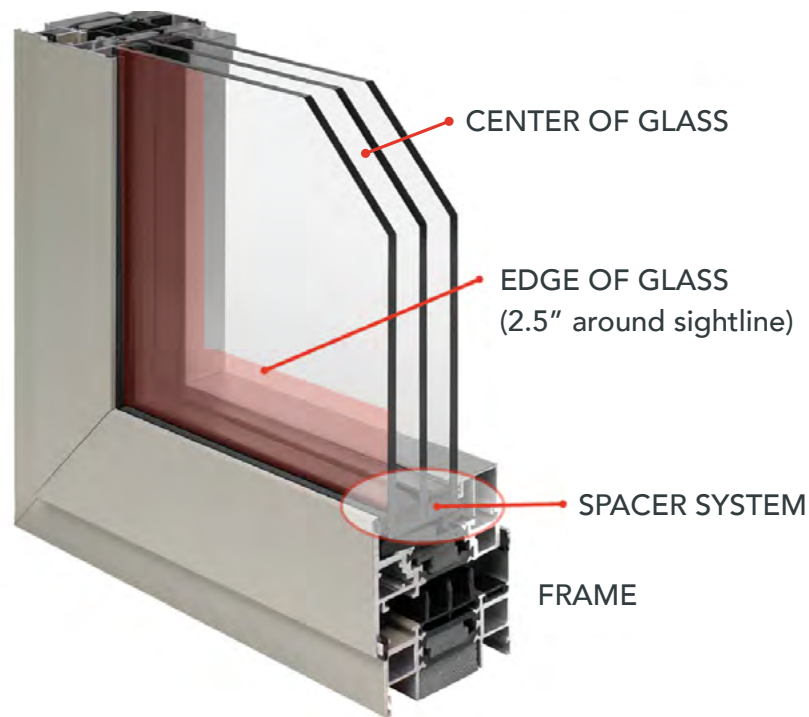

U-FACTOR AND RELATIONSHIP WITH SPACER SYSTEM:

Overall product U-factor is determined by the area weighted average of the heat transfer across three regions of the product: frame, center of glass and edge of glass performances – as per NFRC 100 method*. The lower the U-factor number, the more insulating the product performance. Hence, lower U-factor values are desirable.

As per the industry standard rule, the glazing area 2.5" from the sightline is considered 'edge of glass'. Edge of glass thermal transmittance is heavily influenced by the type of spacer system, and it has a significant impact on the overall product performance.

As expected, an aluminum spacer would conduct more heat, and have higher thermal transmittance compared to a lower conducting polymer or composite edge system.

$$U - \text{Factor (Overall)} = \frac{U_{COG} * A_{COG} + U_{Frame} * A_{Frame} + U_{Edge} * A_{Edge}}{A_{COG} + A_{Frame} + A_{Edge}}$$

Keep in mind, that building energy codes specify compliance targets for the overall product or system's thermal performance, not individual components, for example center of glass, or spacer type.

Kawneer provides overall system performance for different center of glass U-factor values and has thermal performance data for both aluminum and warm-edge spacers, as shown below (On page 4) in an extract from the published thermal chart for the 2500 UT Unitwall® System.

*ANSI/NFRC 100-2020 [E0A0]: Procedure for Determining Fenestration Product U-factors may be obtained from <https://nfrccommunity.org/>

IMPACT OF WARM-EDGE SPACER ON OVERALL U-FACTOR

Note: Overall system U-factors using warm edge spacers with other Keff will differ from those shown.

Lower number is better performance

Table: U-factor (Btu/hr-ft²-°F) impact with spacer selection on 2500 UT Unitwall® System – SGT (Captured version)

GLASS	ALUMINIUM SPACER	WARM-EDGE SPACER*	
COG U-FACTOR	SYSTEM OVERALL U-FACTOR	SYSTEM OVERALL U-FACTOR	
0.28	0.37	0.33	
0.24	0.34	0.30	△ 12% IMPROVEMENT
0.20	0.30	0.26	

HIGHER THERMAL PERFORMANCE

As you can see, for a common double-glazed (low-emissivity coating and argon gas-filled) system with a center of glass U-factor of 0.24 Btu/hr-ft²-°F, the overall product U-factor improved from 0.34 to 0.30 Btu/hr-ft²-°F or by ~12%, just by selecting the warm-edge spacer.*

It makes a significant difference in allowing projects to meet higher thermal performance requirements, using the same product and glazing packages.

SIGNIFICANT IMPACT

Another noteworthy observation from the chart above is the increasingly higher impact on thermal performance from a warm-edge spacer, as the center of glass becomes more insulating (e.g. at lower U-factors).

Given the overall industry trend of using higher and higher insulating products, the warm-edge spacer impact can be significant.

*Effective thermal conductivity (K^{eff}) of the warm-edge spacer assembly used in calculation of overall system U-factor shown is 0.28 W/m.K (0.16 Btu/hr.ft.F). The overall system U-factors using warm-edge spacers with other K^{eff} will differ from those shown.

CONDENSATION RESISTANCE

Additional to improving the U-factor, warm-edge spacers help improve the condensation resistance near the edge of glass area.

See the infrared temperature map of a product cross-section with the same center of glass, but with a different spacer system to visualize the impact of the spacer on the edge temperature. Edge of temperature could be up to 10F warmer with the warm-edge spacer, hence significantly reducing chances of condensation at the intersection of frame and glazing.

EXAMPLE OF FRAME CROSS SECTION TEMPERATURES WITH ALUMINUM VS. WARM-EDGE SPACER

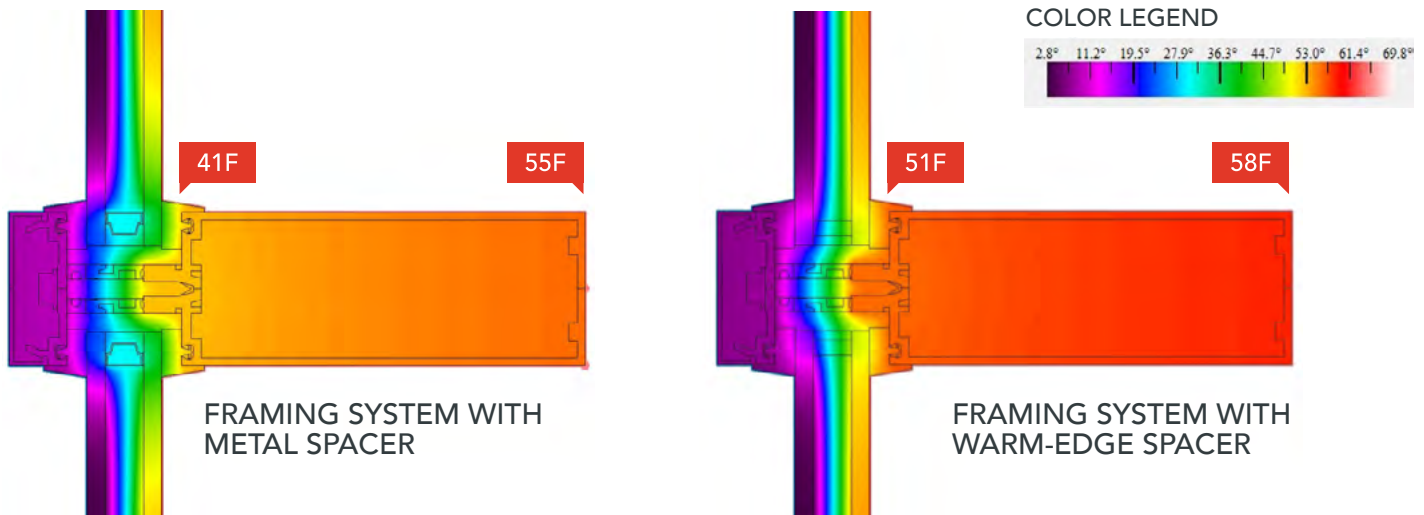

ICISS/ASHRAE 90.1
CLIMATE ZONE

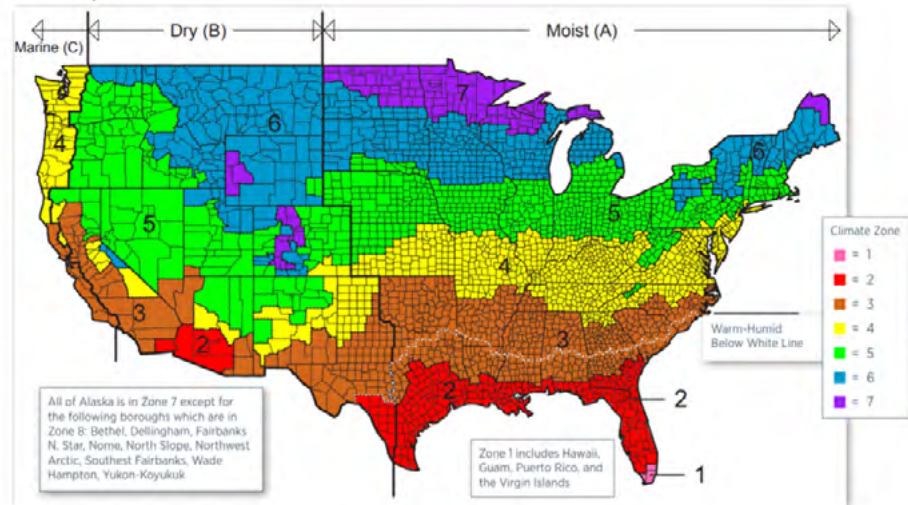

BUILDING ENERGY CODES

Looking at the IECC 2018 prescriptive code requirement for the minimum U-factor of fenestration products (fixed product type e.g., curtain wall, window wall, and operable) – an improvement in U-factor could allow products to qualify in more climate zones, with the same glazing package and selection of a warm-edge spacer.*

Let’s look at the impact of selecting a warm-edge spacer with the Kawneer 1600 Wall System®1 Curtain Wall - which is our industry’s flag-bearer stick build curtain wall system. For a center of glass U-factor of 0.24, the overall product U-factor improves from 0.38 with an aluminum spacer, to 0.35 with the warm-edge spacer, giving ~8% improvement.

Similarly, for a 1600UT System™2 curtain wall system, without any framing design change and a double pane low-e and argon-filled unit (center of glass 0.24), the overall U-factor improves from 0.33 with a metal spacer, to 0.29 with an aluminum-edge spacer.

This gives a ~12% improvement which helps it to qualify for climate zone 7, without any change to the framing system or glass package, simply by selecting the warm-edge spacer.

Table: Minimum U-factor requirements for fixed fenestration products (per IECC 2018 and 2021)

CLIMATE ZONES	2018 IECC	2021 IECC / 90.1-2019
8	0.29	0.26
7	0.29	0.29
6	0.36	0.34
5	0.38	0.36
4	0.38	0.36
3	0.46	0.42
2	0.50	0.45
1	0.50	0.50

*Effective thermal conductivity (K^{eff}) of the warm-edge spacer assembly used in calculation of overall system U-factor shown is 0.28 W/m.K (0.16 Btu/hr.ft.F). The overall system U-factors using warm-edge spacers with other K^{eff} will differ from those shown.



WARM-EDGE SPACER



ALUMINUM EDGE SPACER

ADVANCEMENTS IN GLAZING SPACER TECHNOLOGIES

Insulating glass units consist of two or more panes of glass, with a gap between them. The spacer system bonds the edges of the insulating glass unit, and helps in maintaining the gap between the panes, preventing moisture vapor and gas transmission across the glazing cavity. Spacer systems play a vital role in longevity and durability of any glazing system. Parts of a spacer system include the spacer bar (e.g., metal, thermoplastic, composite or foam), optional primary sealant (PIB), and secondary structural sealant (e.g., silicone). Thermal performance of an assembled spacer system can be defined by the effective thermal conductivity (K^{eff}) and is calculated per NFRC guidelines. Being a single number, effective thermal conductivity makes it easier for evaluating the thermal performances of difference spacer-edge assembly systems.

In commercial glazing, both aluminum and warm-edge spacers use structural silicone for the structural integrity of the glazing unit.

Since insulated glass units came on the market in the 1960s, the aluminum bar spacers have been commonly used. Higher thermal conductivity of the spacer creates a thermal bridge path across the glazing panes around the edges, leading to higher heat transfer and reduced temperature on the interior surfaces, with higher chances of condensation.

A warm-edge spacer is typically referred to as the lower conducting edge bonding system, either with non-metallic, foam or composite materials. This came to market in the 1990s and usage has been increasing steadily. In recent years, growing numbers of commercial glazing fabricators have incorporated warm-edge spacer technology as part of their fabricated glazing offering.

Although Kawneer does not manufacture the glazing spacer system or provide fabricated glazing, we do provide the overall fenestration system's thermal performance data with various center of glass and spacer system types. All leading glazing fabricators have incorporated warm-edge spacer technology into their offering, and spacer manufacturers have been creating awareness in the industry about the availability and benefits of warm-edge spacers.

KAWNEER'S OFFERING

As a system manufacturer, Kawneer provides the system thermal performance data for a range of glazing options, with a U-factor from 0.48 for a simple double-glazed unit, to an advanced triple-glazed unit with a U-factor of as low as 0.10 Btu/hr-Ft²-F, along with spacer system options.

Thermal information for our products are based on the following industry standards.

PHYSICAL THERMAL TEST	THERMAL SIMULATION
✓ NFRC 102	✓ NFRC 100/200/500
✓ AAMA 1503	✓ AAMA 507
✓ ACSA A440	✓ NFRC CMA
	✓ Manufacturer's Certificate of Compliance (CoC)

These thermal, solar, light transmittance, and condensation performances are documented in our architectural detail manual available for download on kawneer.com. In addition, Kawneer framing system components are listed in the NFRC CMA database for project specific performance calculations.

For comparison, we show thermal performance data for our Curtain Wall and Window Wall product offerings using both warm-edge spacer and aluminum spacer options. When using warm edge spacer technology product offerings a Center of glass (CoG) U-factor of 0.24 can be achieved with a low-e coating and argon gas fill.

Note: The results using CMA test methods may differ than those shown using NFRC 100 simulation procedures.



OVERALL SYSTEM U-FACTOR FOR A RANGE OF OUR PRODUCTS

The table below shows the overall U-factor for a range of our products with different assembly types, installation methods, and aesthetic looks.

Overall Product U-Factor with COG 0.24 (low-e coating and argon fill) and warm edge spacer.*

	CAPTURED		2-SIDE SSG		4-SIDE SSG	
	SYSTEM NAME	U-FACTOR	SYSTEM NAME	U-FACTOR	SYSTEM NAME	U-FACTOR
STICK BUILD	1600 System 1	0.39	1600 System 2	0.31	Clearwall SS/SB	0.30
	1600UT System 1	0.32	1600UT System 2	0.29	Clearwall SST/SSIT/SBI/SBIT	0.27
	1620UT System 1	0.32	1620UT SSG	0.29		
	7525	0.29				
SEMI-UNITIZED**	1600UT SS	0.29	1600UT SS Vertical SSG	0.29		
	1600SS	0.39	1600SS SSG	0.31		
	1630 SS IR	0.37				
	1600 System 3	0.35				
	1600 System 4	0.33				
	2250-IF CW	0.43	2250-IG CW	0.35		
UNITIZED	2500UT-SGT	0.30	2500UT-SGT		2500UT-SGT	0.30
	2500PG	0.44	2500PG	0.34	2500PG	0.31
WINDOW WALL	Metroview FG 601T PG	0.34	Metroview FG 601T PG	0.33		
	Metroview FG 501T	0.37				
	PG123	0.32				
	FG623	0.35				

*Effective thermal conductivity (Keff) of the warm-edge spacer assembly used in calculation of overall system U-factor shown is 0.28 W/m.K (0.16 Btu/hr.ft.F). The overall system U-factors using warm-edge spacers with other Keff will differ from those shown.

**SEMI-UNITIZED = Stick Build Screw Spline (SS), or Inside Glazed (IG) Curtain Wall

OVERALL SYSTEM U-FACTOR FOR A RANGE OF OUR PRODUCTS

The table below shows the overall U-factor for a range of our products with different assembly types and installation methods when used with warm-edge spacers.

Overall System U-Factor with COG 0.24 (low-e coating and argon fill) and warm edge spacer.*

DOUBLE GLAZED			
SYSTEM NAME	CONFIGURATION	U-FACTOR	
WINDOWS	5500 Thermal	Fixed	0.31**
	5525 Thermal	Fixed	0.32**
	516 Thermal	Fixed	0.33
	518 Thermal	Fixed	0.34
	526 Thermal	Project-In	0.42
		Project-Out	0.45
	AA®6400/6500/6600 Thermal	Fixed	0.30
	8225TL Thermal	Fixed	0.33
		Project-In	0.45
		Project-Out	0.48
	8400TL Thermal	Fixed	0.35
		Single Hung Vertical	0.46
	GLASSvent® from curtain wall	Projecting (Awning – Single)	0.48
		Casement (Single Vent)	0.48
	GLASSvent® UT	Project-Out	0.37**
		Casement-Out	0.35**
OptiQ® AA®4325	Contact Architectural Sales Representative	0.17 - 0.28	
OptiQ® AA®5450	Contact Architectural Sales Representative	0.21 – 0.34	
STOREFRONT	SYSTEM NAME	GLASS APPLICATION	U-FACTOR
	Trifab® VersaGlaze® 451T	Front Set	0.34
		Center Set	0.33
	Trifab® 451UT	Center Set	0.31
	Trifab® VersaGlaze® 601T	Front Set	0.36
		Center Set	0.35
	Trifab® VersaGlaze® 601UT	Front Set	0.33
		Center Set	0.33
	IR 521UT	Outside Glazed, Inside Glazed	0.37

*Effective thermal conductivity (Keff) of the warm-edge spacer assembly used in calculation of overall system U-factor shown is 0.28 W/m.K (0.16 Btu/hr.ft.F). The overall system U-factors using warm-edge spacers with other Keff will differ from these shown.

**When triple glazed: 5500 and 5525 Thermal Windows in fixed configuration have a U-factor of 0.30. GLASSvent® UT Thermal Windows have a U-factor of 0.35 in project-out configuration and 0.32 in casement-out configuration.

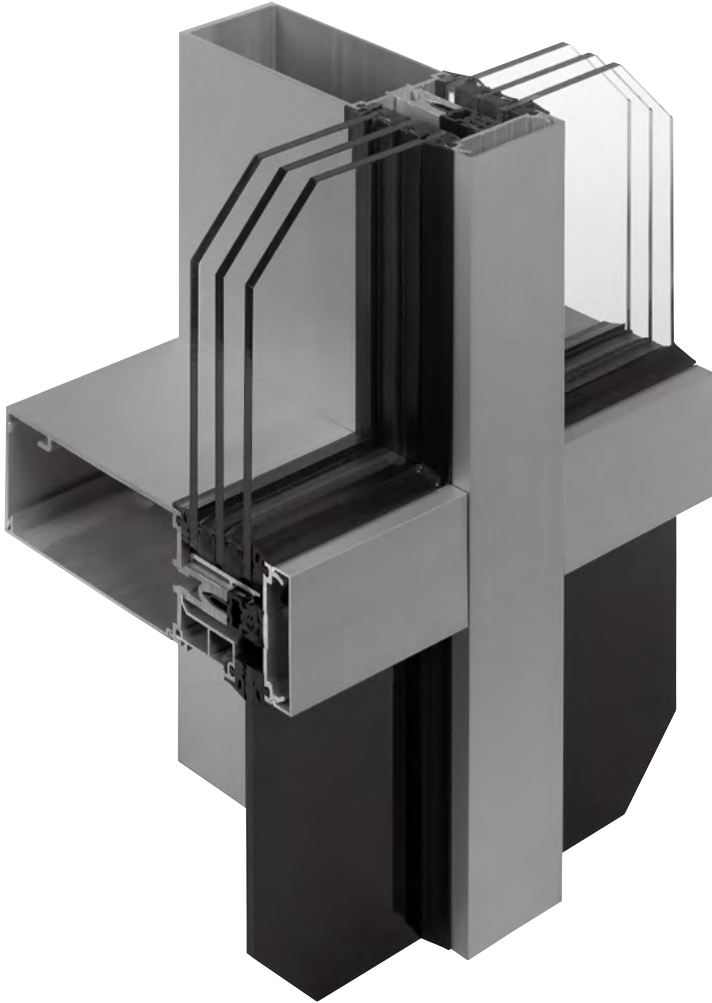

TRIPLE GLAZING CAPABILITY

For projects aiming to achieve an even higher thermal performance, we have a triple glazing capability with several of our products, for example: 1600UT System™1 and System™2 curtain wall systems.

Thermal (U-factor) information can be found in our architectural detail manual on Kawneer.com, along with solar heat gain, visual transmittance, and condensation resistance factors. Separate charts have been published for the metal (aluminum) spacer and warm-edge spacer.

These charts also allow professionals to determine product performances (U-factor, SHGC (Solar Heat Gain Coefficient), VT (Visible Transmittance)) based on the project specific sizes by utilizing glass to frame ratios.

For specific project submittals, customers can generate a manufacturer's certificate of compliance (CoC) for thermal and solar performance indices (U-factor, SHGC, VT) through Kawneer's eCommerce portal on KawneerDirect.com.

Stay tuned as we add more products with warm-edge spacer data.

SOURCES:

- https://www.energy.gov/sites/prod/files/2015/10/f27/ba_climate_region_guide_7.3.pdf
- [2018 International Energy Conservation Code - CHAPTER 4 \(icc-safe.org\)](#)

MEETING THE MASSACHUSETTS STRETCH CODE OF 0.25 U-FACTOR

Kawneer products can help meet Massachusetts Stretch code for the vision portion of glazed wall fenestration products where U-factor of 0.25 is required. Glazed wall products include curtain wall, window wall and ribbon windows, and store-front products.

Typical double- and triple-glazing options and their center-of-glass U-factors

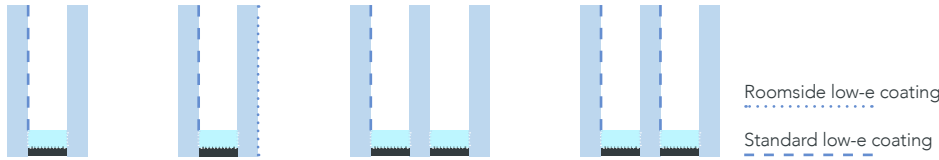

DOUBLE GLAZED		TRIPLE GLAZED	
COG: 0.24	COG: 0.20	COG: 0.18	COG: 0.12

*These numbers are achieved through argon gas filled glass units.

Addition of room-side low-e coating on a double-glazed unit can reduce the center-of-glass (COG) U-factor to 0.20; however, aesthetic and condensation impacts must be assessed prior to selecting such glazing.

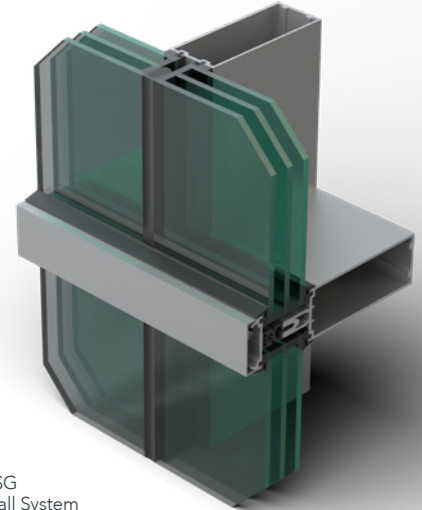

1620UT SSG
Curtain Wall System

DOUBLE GLAZING U-FACTORS		COG: 0.20
CURTAIN WALL	Clearwall® SBIT	0.23
	Clearwall® SSI / SSIT / SBI	0.24
	1620UT SSG	0.25**
	1620UT SS Captured	0.25***
	1600UT SS 4-Side Captured	0.25
	1600UT SS Vertical SSG	0.24***
	1620UT System 1	0.26**
	7525 Wall	0.26
	1600UT System™ 2	0.26
	1620UT SSG	0.26
WINDOW WALL	OptiQ® AA®4325 Ribbon Window	0.25

System U-factor using double glazing with additional room-side low-e coating and warm-edge glazing spacer (with aluminum pressure plate for stick curtain wall where applicable)

TRIPLE GLAZING U-FACTORS		COG: 0.18	COG: 0.12	
CURTAIN WALL	1620UT SSG	0.23	0.18	
	1600UT System™ 2	0.24	0.17	
	2500 UT / 2500 UT SGT	0.24	0.19	
	7550 Wall	0.24	0.16	
	1600UT System™ 1	0.27	0.22	
	1620UT System 1	0.27	0.22	
	WINDOW WALL	OptiQ® AA®4325 Ribbon Window	0.22	0.17
		OptiQ® AA®5450 Ribbon Window	0.25	0.20
OptiQ® AA®6400 Ribbon Window		0.25	0.20	

Overall system U-factor using triple glazing options of single and double low-e coatings and warm edge glazing spacer (with aluminum pressure plate for stick curtain wall where applicable)

These numbers are based on NFRC standard size. Actual project area-weighted average U-factor may change.
For relatively larger glazing to frame ratio projects, U-factor will be reduced and may be able to achieve 0.25 requirements.
**With fiberglass pressure plate. (1600UT System 1 U-factor will be similar to 1620UT)
***With backer rod above glass

For any questions, please contact the local Architectural Sales Representatives, Douglas Craven, at Douglas.Craven@arconic.com or 413-455-9036, or John Boccuzzi, at John.Boccuzzi@arconic.com or 860-416-7130.

MEETING THE SEATTLE STRETCH CODE OF 0.22 U-FACTOR

Kawneer products can help meet Seattle Stretch code for the vision portion of glazed wall fenestration products where U-factor of 0.22 for fixed glazing and 0.26 for operable glazing is required for 20% of a building. Glazed wall products include curtain wall, window wall and ribbon window products.

Typical double- and triple-glazing options and their center-of-glass U-factors*

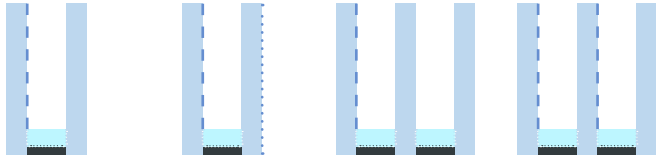

Room-side low-e coating
Standard low-e coating

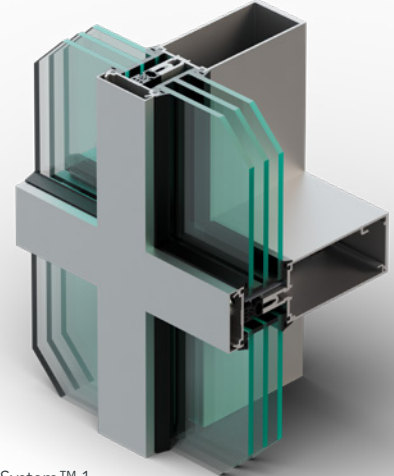

1600UT System™ 1
Curtain Wall

DOUBLE GLAZED		TRIPLE GLAZED	
COG: 0.24	COG: 0.20	COG: 0.18	COG: 0.12

*These numbers are achieved through argon gas filled glass units.

Addition of room-side low-e coating on a double-glazed unit can reduce the center-of-glass (COG) U-factor to 0.20; however, aesthetic and condensation impacts must be assessed prior to selecting such glazing.

OPERABLE TRIPLE GLAZING U-FACTORS			
WINDOW	CONFIGURATION	COG: 0.18	COG: 0.12
OptiQ® AA® 4325	Project In	0.25	0.22
	Project Out	0.30	0.26
OptiQ® AA® 5450	Single Hung	0.29	0.24
	Double Hung	0.31	0.26
	Horizontal Sliding	0.29	0.24
GLASSvent® UT	Project Out	0.30	0.26
	Outswing Casement	0.29	0.23

Overall system U-factor using triple glazing options of single and double low-e coatings and warm edge glazing spacer

DOUBLE GLAZING U-FACTORS		COG: 0.20
CURTAIN WALL	Clearwall SBIT	0.23

Overall system U-factor using double glazing with additional room-side low-e coating and warm-edge glazing spacer

TRIPLE GLAZING U-FACTORS		COG: 0.18	COG: 0.12
CURTAIN WALL	1620UT SSG	0.23	0.18
	1600UT System™ 2	0.24	0.17
	2500 UT / 2500 UT SGT	0.24	0.19
	7550 Wall	0.24	0.16
	1600UT System™ 1	0.27	0.22**
	1620UT System 1	0.27	0.22
WINDOW WALL	OptiQ® AA® 4325 Ribbon Window	0.22	0.17
	OptiQ® AA® 5450 Ribbon Window	0.25	0.20
	AA® 6400 Ribbon Window	0.25	0.20

Overall system U-factor using triple glazing options of single and double low-e coatings and warm edge glazing spacer (with aluminum pressure plate for stick curtain wall where applicable)

**With fiberglass pressure plate.

These numbers are based on NFRC standard size. Actual project area-weighted average U-factor may change. For relatively larger glazing to frame ratio projects, U-factor will be reduced and may be able to achieve 0.22 requirements.

These numbers are based on NFRC 100/AAMA 507 thermal simulations and may differ from CMAST.

For any questions, please contact the local Seattle Sales Representative, Cameron Ernotte, at cameron@windowtechinc.com or 425-778-2050.

BUILDING LEGACIES

Thermal performance will continue to be a trend for years to come. As market requirements shift, the need for thermal performance remains a constant. Kawneer is always pushing the envelope when it comes to delivering innovative, high-performing thermal solutions.

Our standards of success are high to ensure we meet your needs. We build on the past to advance the future to help build your legacy.

©Kawneer Company, Inc. 2024
Form No. 21-2348

Technology Park/ Atlanta
555 Guthridge Court
Norcross, GA 3009-3503

770.449.555 TEL
770.734.1560 FAX

www.kawneer.com